

B26B frame & grate shown
 H20 load rating
 Effective height of casting: 65mm

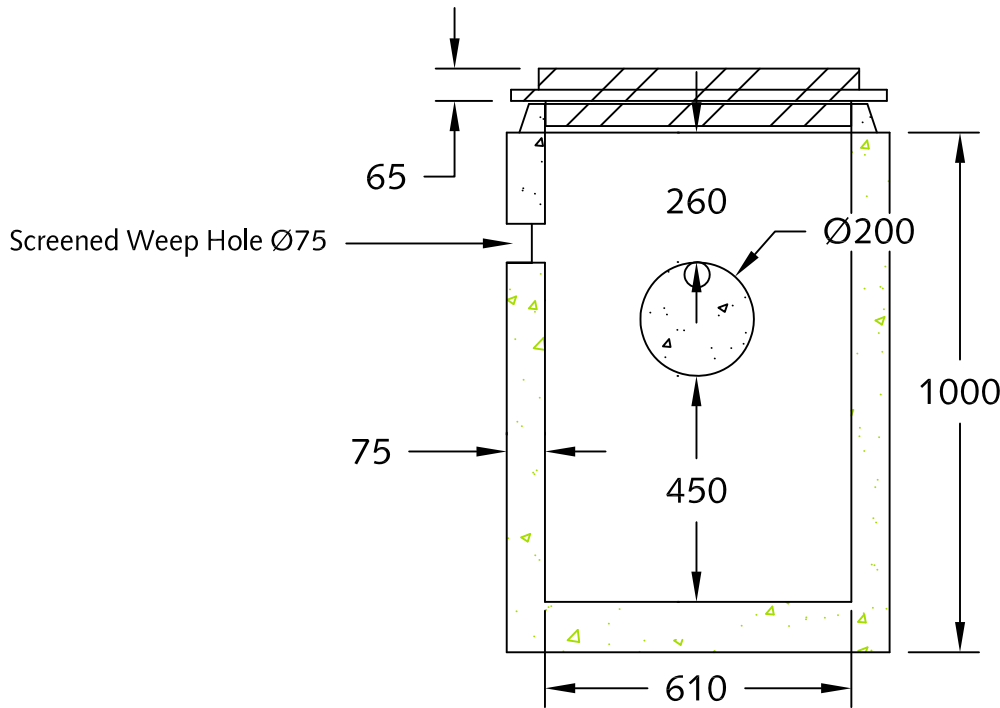

Notes:

1. Recommended for parking lot applications as shown.
2. Min. concrete strength: 27.5 MPa.
3. Comes with 150mm base, 200mm core, 75mm weeping hole.
4. Available with trapping hood pins upon request.
5. Manufactured to ASTM C478 standard.
6. Approx. weight: 550 kgs.
7. All dimensions are in millimeters.



DESCRIPTION:

Ø600x1000
 Standard Catchbasin
www.langleyconcretegroup.com

DRAWN BY: JAO

ORIGIN: CHWK

SCALE: 1:15

DRAWING NO:

DATE: Apr/08/2010

CB-1a

This drawing is the property of the Langley Concrete Group of Companies. All information contained herein is confidential and may not be used in whole or in part without written permission from the owner.

LANGLEY (604)533-1656

VICTORIA (250) 478-9581

CHILLIWACK (604) 533-1656