

Plan View

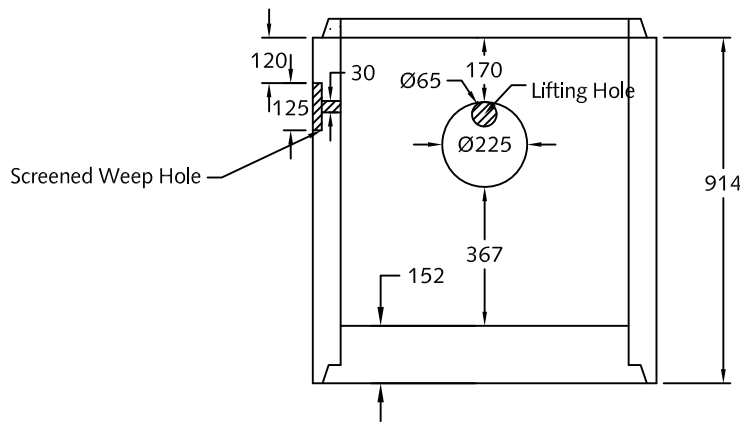

Section A-A

Notes:

1. Reinforced 750x900 catchbasin w/base & core as shown.
2. Core to be 225Ømm as shown.
3. Screened weeping hole provided as shown.
4. Lifting hole supplied opposite to core as shown.
5. Approx. weight: 1062 kgs[2340lbs].
6. Min. concrete strength: 27.6 MPa.



DESCRIPTION:

750x900C478
 Catchbasin
www.langleyconcretegroup.com

DRAWN BY: JAO ORIGIN: CHWK

SCALE: 1:20 DRAWING NO:

DATE: Mar/24/2002 CB0.75x0.9WB

This drawing is the property of the Langley Concrete Group of Companies. All information contained herein is confidential and may not be used in whole or in part without written permission from the owner.