

Plan View

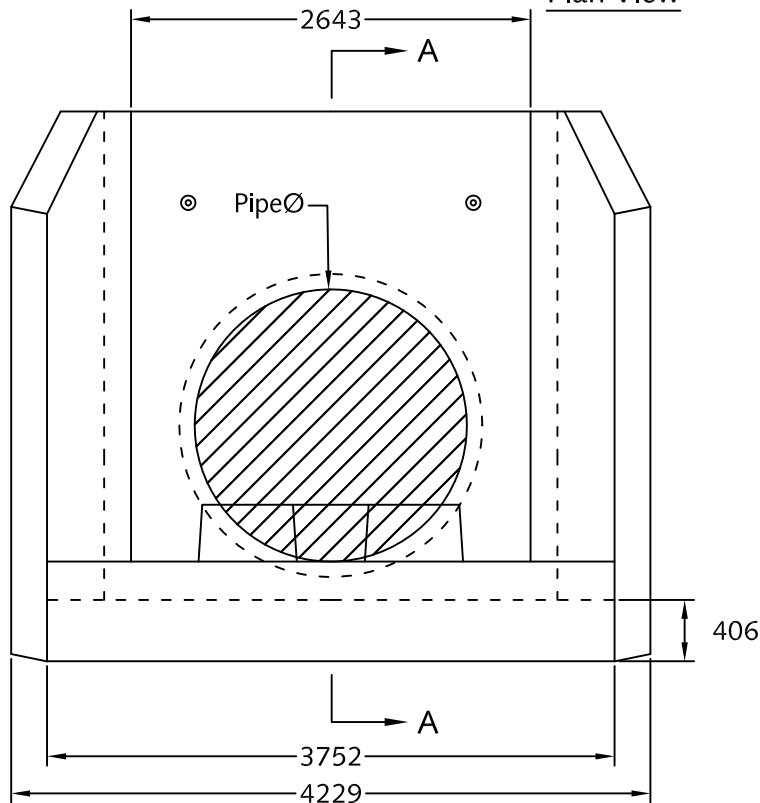

Elevation View

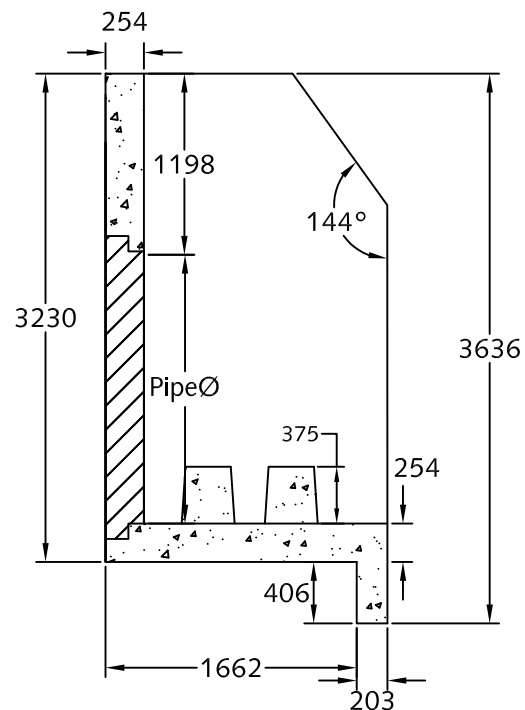

Section A-A

Notes:

1. HW 26-28 to be built as shown.
2. Unit c/w Energy dissipator blocks as shown.
3. Unit c/w rough core for inlet & outlet as shown.
4. Suggested for pipe sizes to a maximum of 1800 mm diameter.
5. Structure c/w bolt anchors for grills and handrails.
6. Bolt on Inlet or Outlet grills and handrails are available upon request.
7. Backwall height can be manufactured to varying heights as required to suit jobsite conditions.
8. Unit c/w lifting inserts as required.
9. Approximate weight: 12500 kg.
10. Minimum rebar yield strength: 414 MPa.
11. Minimum concrete strength: 28 MPa.
12. All dimensions are in millimeters.



DESCRIPTION:

HW 26-28
w/ Energy Dissipator
www.langleyconcretegroup.com

DRAWN BY:	KS	ORIGIN:	CHWK
CHK BY:	JAO/SW	DWG NO:	HW26-28-ED
DATE:	DEC/17/2009	REV DATE:	2. JULY/15/2010
SCALE:	1:50		

This drawing is the property of the Langley Concrete Group of Companies. All information contained herein is confidential and may not be used in whole or in part without written permission from the owner.