

Plan View

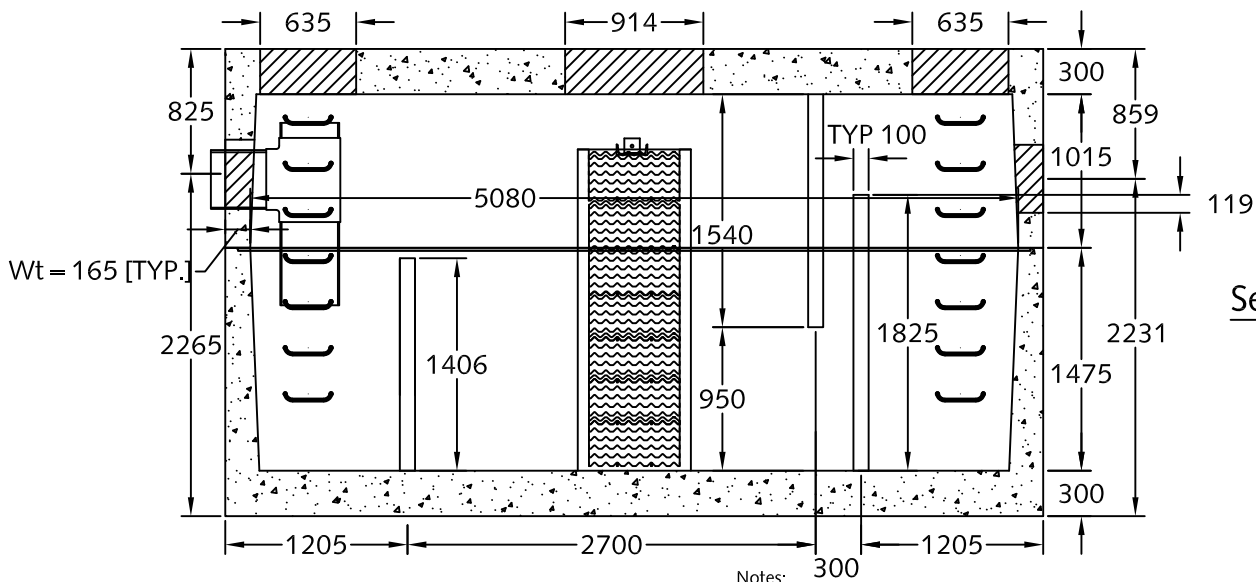

Section A-A

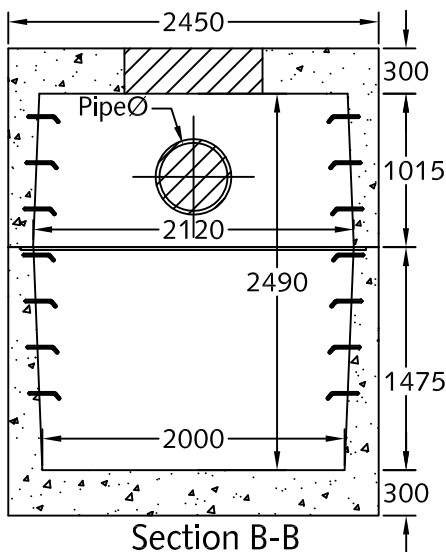

Section B-B

Notes:

1. 5212.5 Oil interceptor [API Style] manufactured to meet AASHTO HS20 live loading.
2. Unit dimensions are 5.0 x 2.1 x 2.5 m.
3. Reinforced concrete lid manufactured for AASHTO HS20 live loading.
4. Unit c/w rough cores for inlet/outlets as required.
5. Unit c/w 2-Ø635, 1-Ø914 mm opening for accesses as shown.
6. Oil interceptor c/w 102 mm thick concrete baffles as shown.
7. Unit has a maximum 17,800 liter [ 17.8 m<sup>3</sup> ] capacity.
8. Unit c/w lifting inserts as required.
9. Unit c/w ladder rungs upon request.
10. PVC required by design, installed by others in field.
11. Design can be modified for specific application, please contact LCG sales office.
12. Approximate weight:
  - Top section: 18,885 kg.
  - Bottom section: 22,850 kg.
13. Minimum rebar yield strength: 414 MPa.
14. Minimum concrete strength: 35 MPa.
15. All dimensions are in millimeters.
16. Unit design to:
  - Temp.: 0°C.
  - Oil S.G.: 0.85.
  - Influent oil = 100 mg/l.
  - Effluent oil < = 15 mg/l.
  - Max flow: 41 l/s.



DESCRIPTION:

5212.5 Coalescing Plate Oil Interceptor  
16 mm Spacing

www.langleyconcretegroup.com

DRAWN BY:	KS	ORIGIN:	CHWK
CHK BY:	SW	DWG NO:	5212.5-COI-16
DATE:	JUNE/18/2010	REV DATE:	2. NOV/01/2010
SCALE:	1:50		

This drawing is the property of the Langley Concrete Group of Companies. All information contained herein is confidential and may not be used in whole or in part without written permission from the owner.