

Plan View

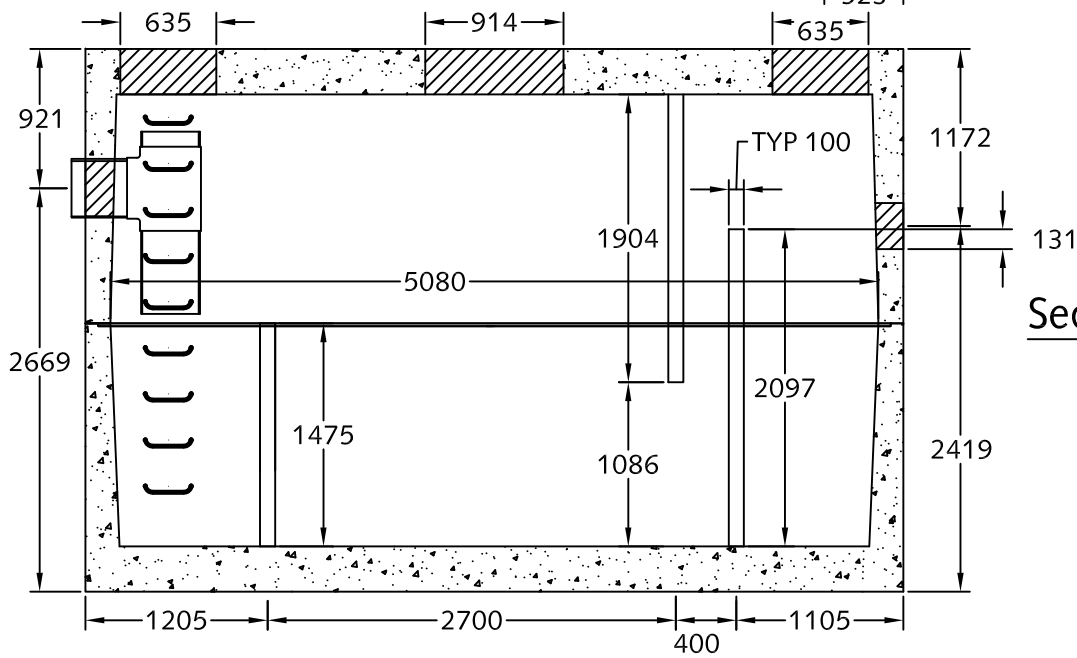

Section A-A

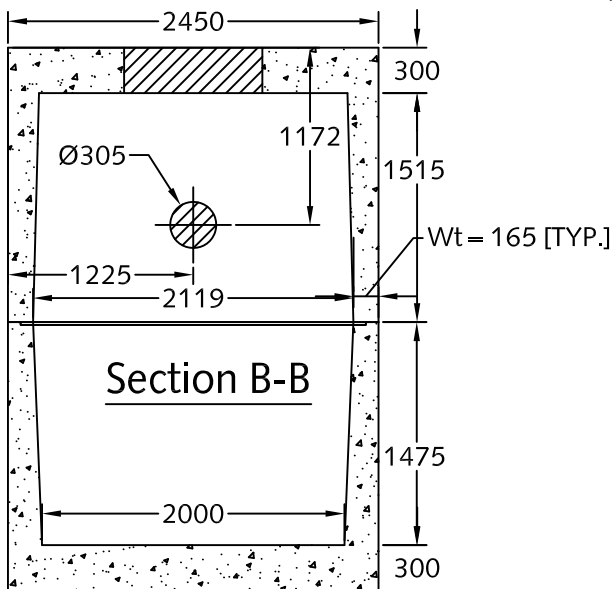

Notes:

1. 5213 Oil interceptor [API Style] manufactured to meet AASHTO HS20 live loading.
2. Unit dimensions are 5.0 x 2.1 x 3.0 m.
3. Reinforced concrete lid manufactured for AASHTO HS20 live loading.
4. Unit c/w rough cores for inlet/outlets as required.
5. Unit c/w 2-Ø635, 1-Ø914 mm opening for accesses as shown.
6. Oil interceptor c/w 102 mm thick concrete baffles as shown.
7. Unit has a maximum 21,600 liter [21.6 m³] capacity.
8. Unit c/w lifting inserts as required.
9. Unit c/w ladder rungs upon request.
10. PVC required by design, installed by others in field.
11. Design can be modified for specific application, please contact LCG sales office.
12. Approximate weight:
 - Top section: 23,525 kg.
 - Bottom section: 24,245 kg.
13. Minimum rebar yield strength: 414 MPa.
14. Minimum concrete strength: 35 MPa.
15. All dimensions are in millimeters.



DESCRIPTION:

5213 Oil Interceptor
API Style

www.langleyconcretegroup.com

| | | | |
|-----------|-------------|-----------|----------------|
| DRAWN BY: | KS | ORIGIN: | CHWK |
| CHK BY: | JAO/SW | DWG NO: | 5213-API-1.0 |
| DATE: | FEB/24/2010 | REV DATE: | |
| SCALE: | 1:50 | | 2. NOV/01/2010 |

This drawing is the property of the Langley Concrete Group of Companies. All information contained herein is confidential and may not be used in whole or in part without written permission from the owner.