

Plan View

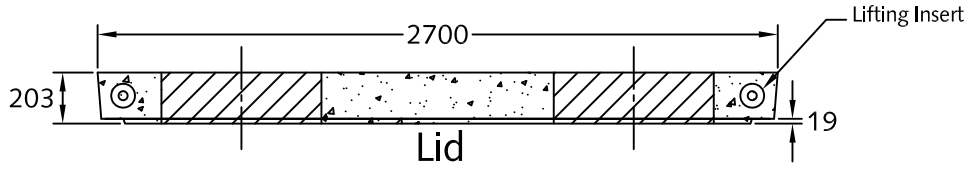

Lid

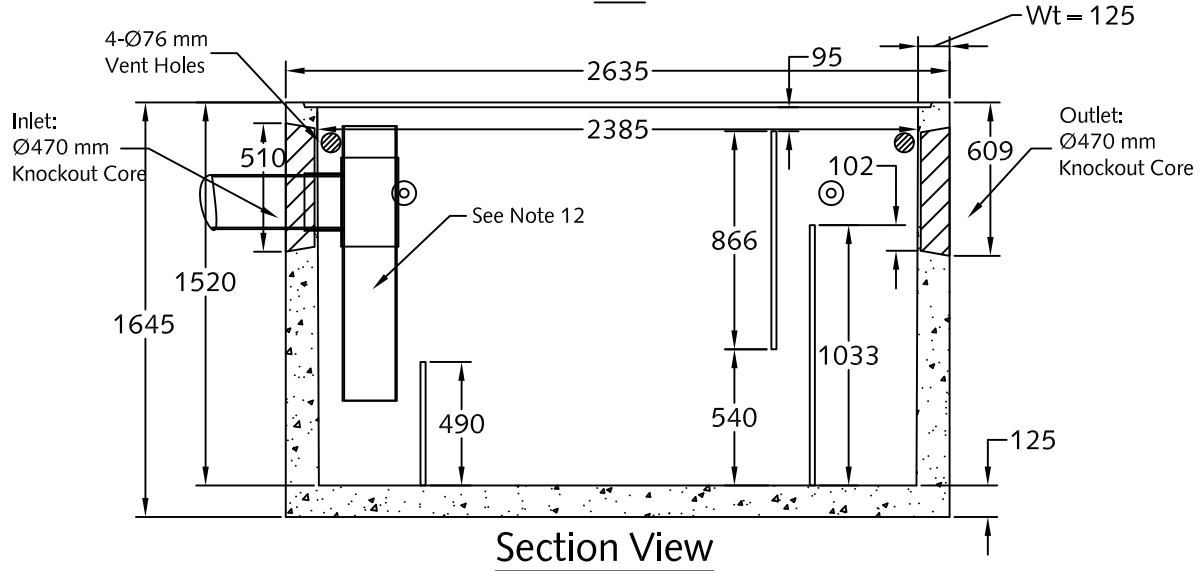

Section View

Notes:

1. Type II Oil interceptor [API Style] manufactured to meet AASHTO HS20 live loading.
2. Unit dimensions are 2.38 x 0.92 x 1.52 m.
3. Reinforced concrete lid manufactured for AASHTO HS20 live loading.
4. Unit c/w Ø470 mm knockout cores for inlet/outlets as shown.
5. Unit risers available in heights: 300, 450 etc. to 1050 mm maximum.
6. Unit c/w 2-Ø635 mm opening for accesses as shown.
7. Unit supplied w/ 4-Ø76 mm vent holes as shown.
8. Oil interceptor c/w 12 gauge galvanized baffles as shown.
9. Unit has a maximum 2,000 liter [2.0 m<sup>3</sup>] capacity.
10. Unit c/w 5T lifting inserts as shown.
11. Unit c/w ladder rungs upon request.
12. PVC required by design, installed by others in field.
13. Design can be modified for specific application, please contact LCG sales office.
14. Approximate weight:
  - Lid: 1,350 kg.
  - Chamber: 4,220 kg.
15. Minimum rebar yield strength: 414 MPa.
16. Minimum concrete strength: 35 MPa.
17. All dimensions are in millimeters.



DESCRIPTION:  
**TYPE II**  
**Oil Interceptor [API]**  
**w/ Dual Access Concrete Lid**  
[www.langleyconcretegroup.com](http://www.langleyconcretegroup.com)

DRAWN BY:	KS	ORIGIN:	CHWK
CHK BY:	JDB/SW/JAO	DWG NO:	TYPE II-API-1.0
DATE:	DEC/04/2009	REV DATE:	4. NOV/01/2010
SCALE:	1:30		

This drawing is the property of the Langley Concrete Group of Companies. All information contained herein is confidential and may not be used in whole or in part without written permission from the owner.