

Plan View

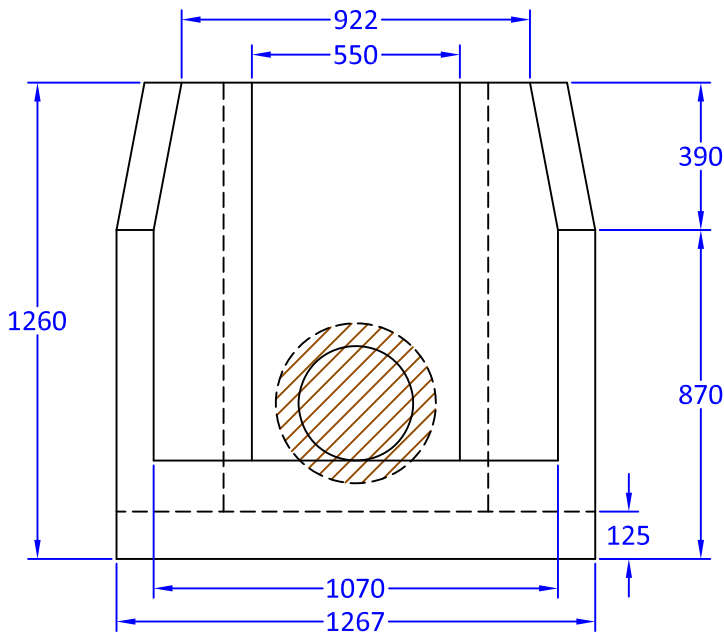

Elevation View

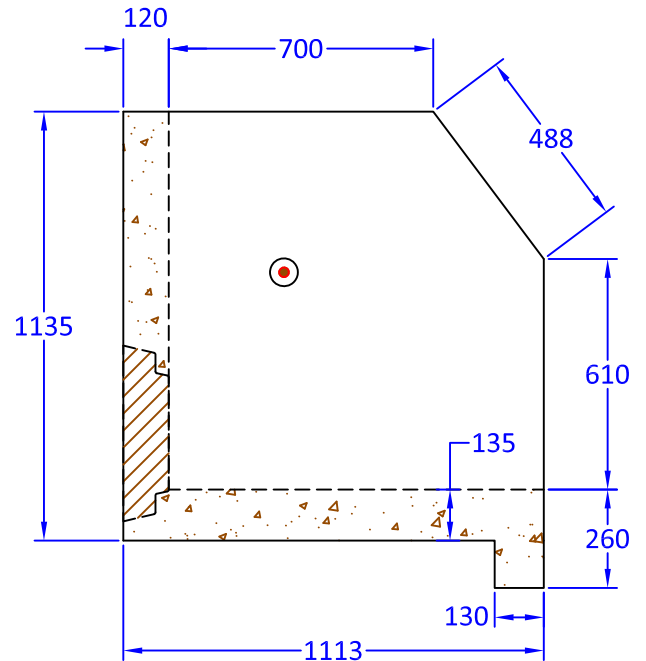

Wing Wall Detail

Notes:

1. Type II headwall is built as shown.
2. Unit supplied with rough core for inlet/outlet as shown.
3. Suggested core size to be maximum of 400mm diameter.
4. Unit supplied with lifting inserts as required.
5. Structure supplied with embedded threaded inserts for grills and handrails.
6. Approximate weight: 1,010kg.
7. Minimum rebar yield strength: 414 MPa.
8. Minimum concrete strength: 30 MPa.
9. All dimensions are in millimeters.



Quality Assurance of products manufactured by The Langley Concrete Group has been verified by the following third party certification programs:



The LANGLEY CONCRETE Group of Companies
www.langleyconcretegroup.com

LANGLEY (604) 533-1656 VICTORIA (250) 478-9581 CHILLIWACK 1-800 667-9600

DESCRIPTION:

Type II Headwall Structure

DRAWN BY: KK	JOB NO.:
CHK BY: KS	DWG NO: HW-TII-1.0
DATE: July 09,2018	REV.
SCALE: 1:20	LCG Products are held to the governing ASTM, and CSA specification & tolerances.
<small>This drawing is the property of the Langley Concrete Group of Companies. All information contained herein is confidential and may not be used in whole or in part without written permission from the owner.</small>	