

Plan View

Standard curb lid to fit TR23/24

Catchbasin will accept TR26B frame & grate  
No lid necessary with TR26B

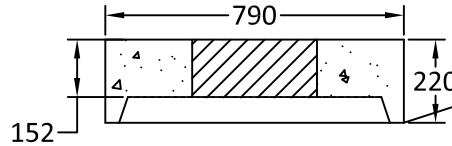

HS-20 highway loading lid, to accept TR 23/24  
Effective height: 150mm  
Lid weight: 123 KG

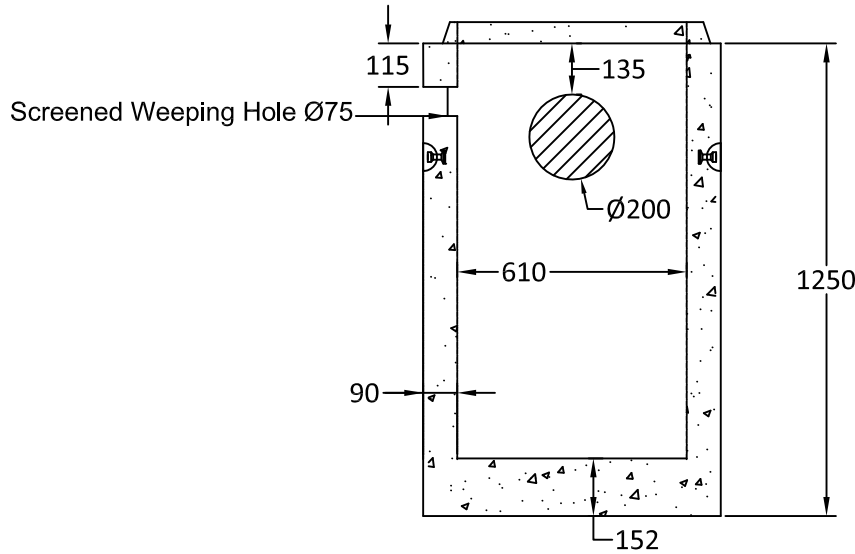

Elevation View

Notes:

1. Catchbasins manufactured to ASTM C478 standards.
2. Ø200mm Knock Out core for Outlet Pipe supplied as shown.
3. Ø75mm Galv. Screened Weep Hole provided as shown.
4. 150mm thick base cast in bottom as shown.
5. Adjustable hood on 23/24 frame shown for reference only.
6. Trapping hood recommended for outlet pipe, pins available on request.
7. Minimum concrete strength: 30 MPa.
8. Approx weight of Catchbasin: 580kgs.
9. All dimensions are in millimeters.



Quality Assurance of products manufactured by The Langley Concrete Group has been verified by the following third party certification programs:



The LANGLEY CONCRETE Group of Companies  
www.langleyconcretegroup.com

DESCRIPTION:

Ø600x1200  
C478 Catch Basin

LANGLEY (604) 533-1656 VICTORIA (250) 478-9581 CHILLIWACK 1-800 667-9600

DRAWN BY: JAO

JOB NO.: N/A

CHK BY:

DWG NO: CB-1

DATE: May 3, 2010

REV. BY: CC  
Aug. 15, 2018

SCALE: 1:20

This drawing is the property of the Langley Concrete Group of Companies. All information contained herein is confidential and may not be used in whole or in part without written permission from the owner.

LCG Products are held to the governing ASTM, and CSA specification & tolerances.