

Lid 750
Weight: 138 Kgs.

H20 loading reinforced lid
Available with openings for:

- B26B frame & grate
- B23/24 frame & grate
- B25A frame & grate
- B19A 'Hwys Style' Frame & Grate
- C18/C20 manhole frame & covers
- Custom openings available

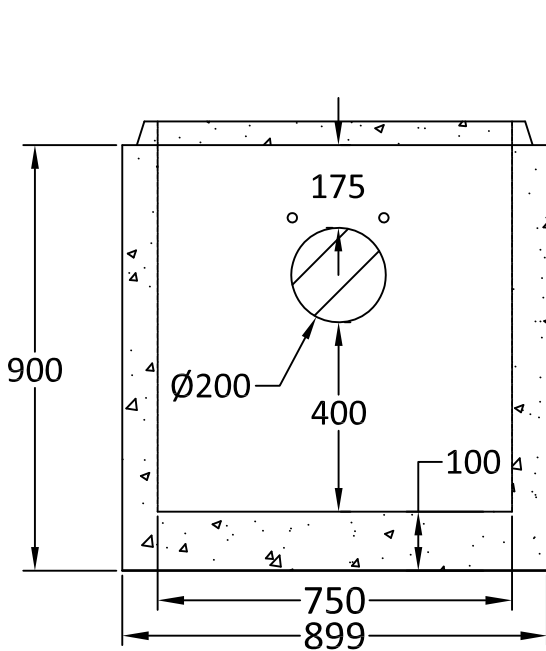

CB 750 X 900
Weight: 590 Kgs.

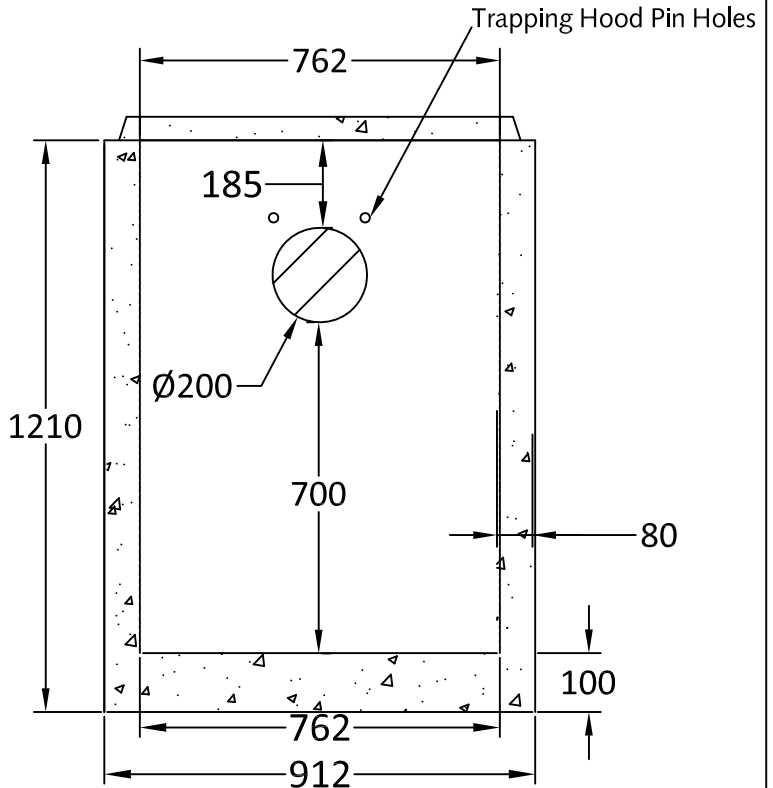

CB 750 X 1200
Weight: 725 Kgs.

Notes:

1. Manufactured to ASTM C478 spec.
2. Min. concrete strength: 27.5 MPa.
3. Available with 2-19mm gal. trapping hood pins.
4. Comes with 100mm thick base.
5. 50mm lift core provided across from outlet core.



The LANGLEY CONCRETE Group of Companies
www.langleyconcretegroup.com

DESCRIPTION:

Highways Style
Ø750 Catch Basins

DRAWN BY: JAO

JOB NO.: N/A

CHK BY:

DWG NO: Cb-HWY

DATE: June 30, 2005

REV. BY:

SCALE: 1:16

This drawing is the property of the Langley Concrete Group of Companies. All information contained herein is confidential and may not be used in whole or in part without written permission from the owner.

LCG Products are held to the governing ASTM, and CSA specification & tolerances.