

PARTLIST			
ITEM	QTY	PART NUMBER	WEIGHT
1	1	Headwall	3,000 kg.

Notes:

1. 11-13 Headwall is built as shown.
2. Unit supplied with energy dissipator blocks as shown.
3. Unit supplied with rough core for inlet/outlet as shown.
4. Suggested core size to be maximum of 915mm diameter.
5. Structure supplied with embedded threaded inserts for grills and handrails.
6. Bolt-on inlet/outlet grills and handrails are available upon request.
7. Unit supplied with lifting inserts as required.
8. Minimum rebar yield strength: 414 MPa.
9. Minimum concrete strength: 30 MPa.
10. All dimensions are in millimeters.

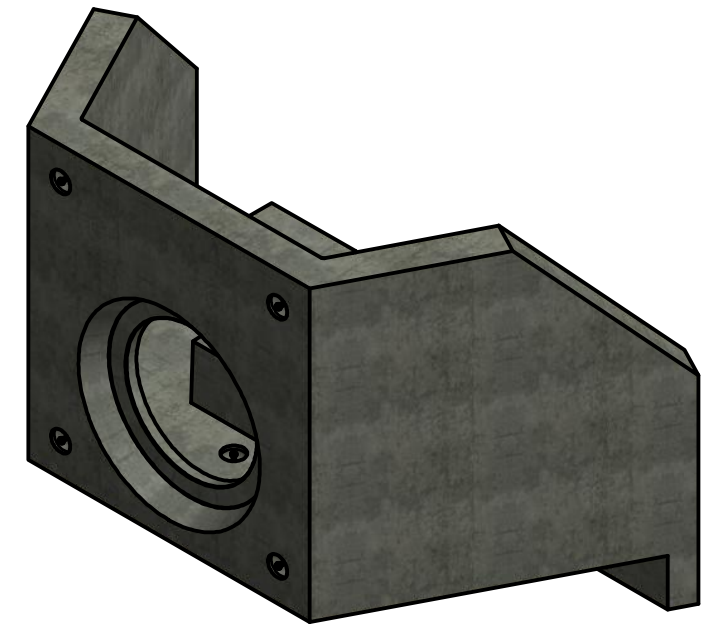
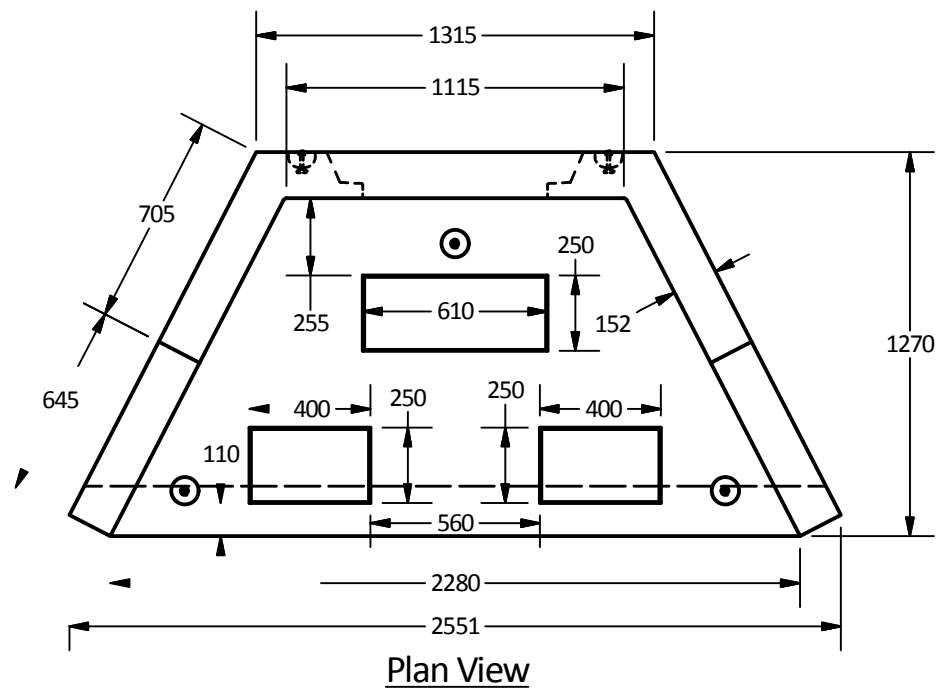

Isometric View

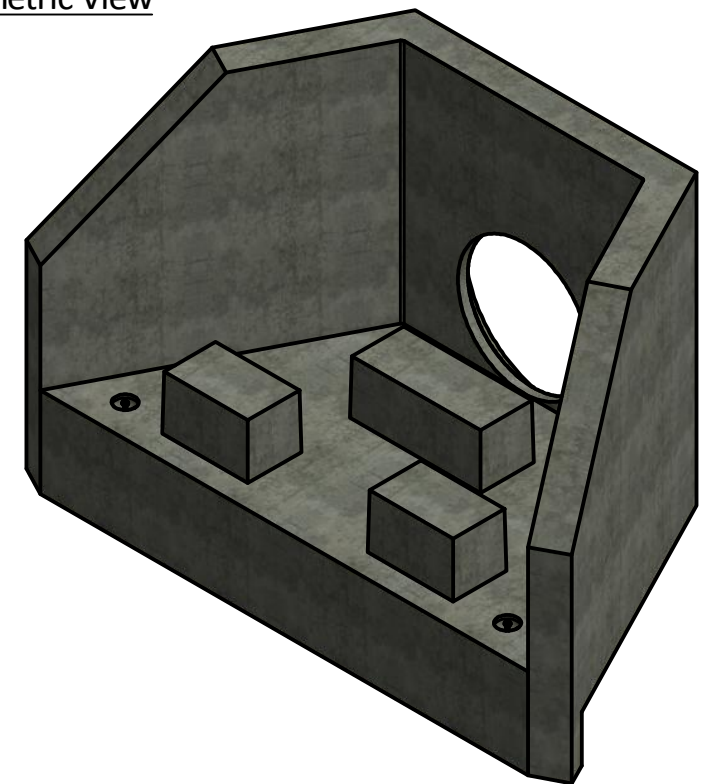
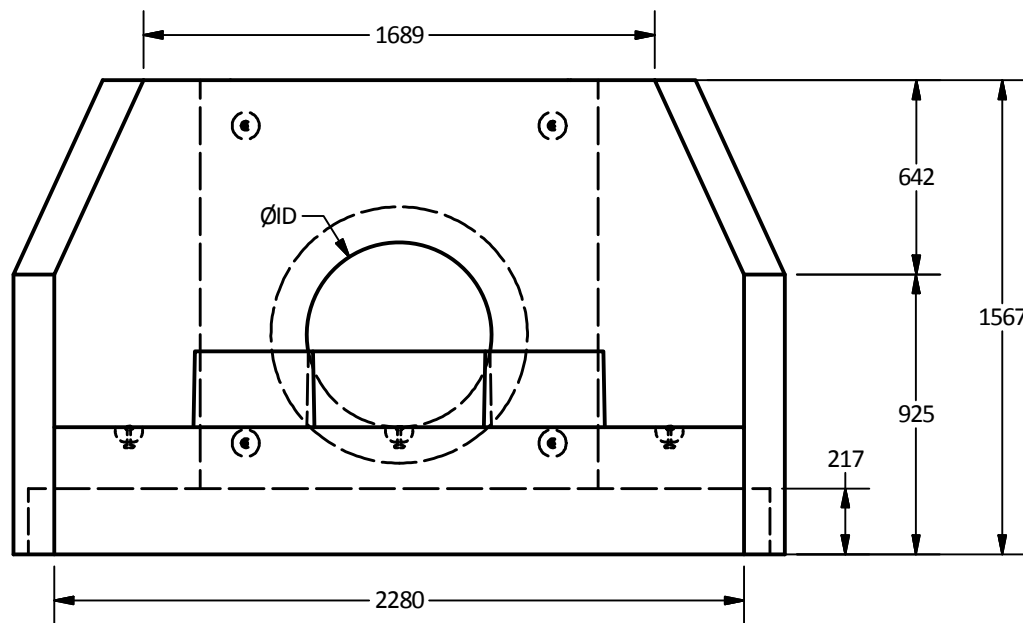
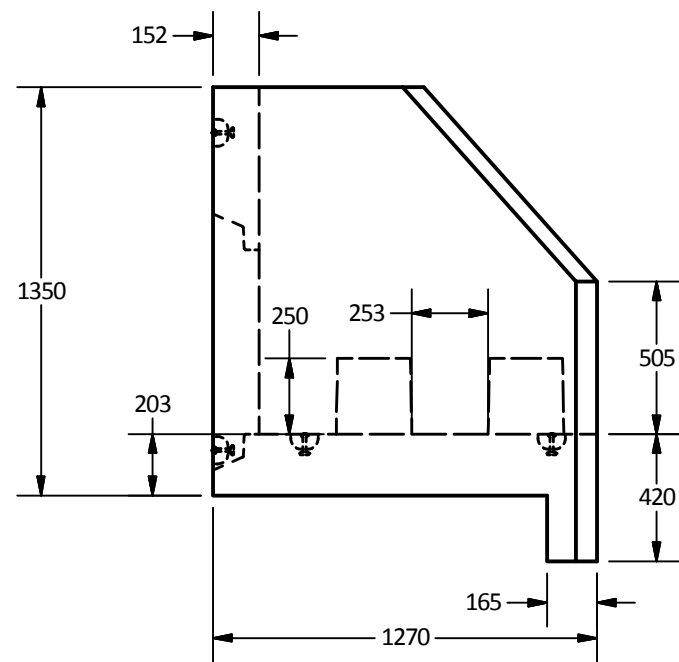

Langley Concrete Group is a certified Q-Cast Plant, an American Concrete Pipe Association Third Party Certification for the manufacture of Pipe, Manhole, Box Culvert & Precast Items.



Quality Assurance of products manufactured by The Langley Concrete Group has been verified by the following third party certification programs



All Dimensions are in Millimeters. Unless otherwise Stated

Projection Method: THIRD ANGLE



LANGLEY (604) 533-1656
VICTORIA (250) 478-9581
CHILLIWACK 1-800 667-9600

This drawing is the property of the Langley Concrete Group of Companies. All information contained herein is confidential and may not be used in whole or in part without written permission from the owner

DESCRIPTION:

11-13 Headwall Structure with Energy Dissipator Block

DRAWN BY: SR	JOB NO.
CHK BY: KS	DWG NO: HW-11-13-ED
DATE: July.23, 2018	
SCALE: 1:25	
SIZE 11 x 17	REV.
	SHEET 1 OF 1