

Note:

1. Ø3050 Manhole manufactured to ASTM C478 specification.
2. Concrete designed to withstand HS20, BCL 625 live loadings.
3. Unit supplied with cores as required.
4. Unit supplied with ladder rungs as required.
5. Unit supplied with lifting insert as required.
6. Unit supplied with access opening as required.
7. WWF minimum yield strength: 448 MPa.
8. Minimum rebar yield strength: 414 MPa.
9. Minimum concrete strength: 35 MPa.
10. All reinforcing to have minimum 25 mm of concrete cover.
11. All dimensions are in millimeters.

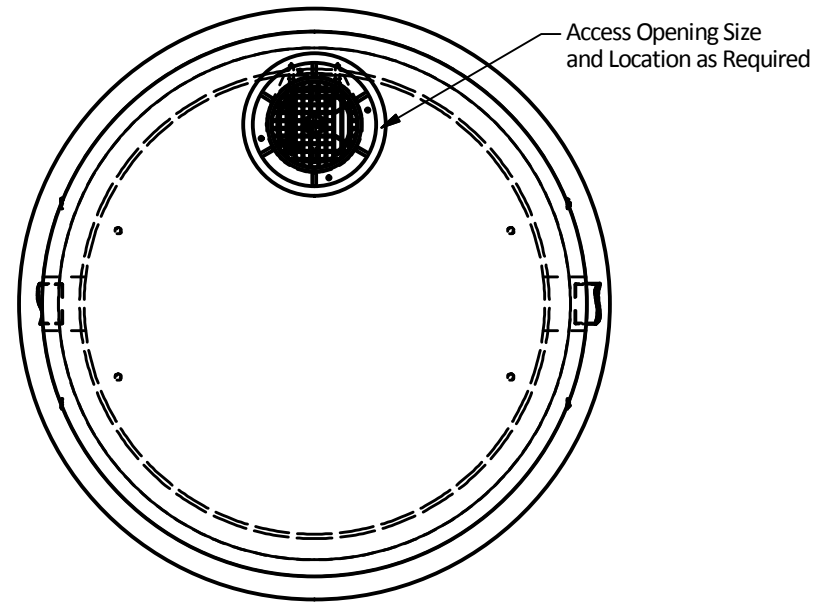

Plan View

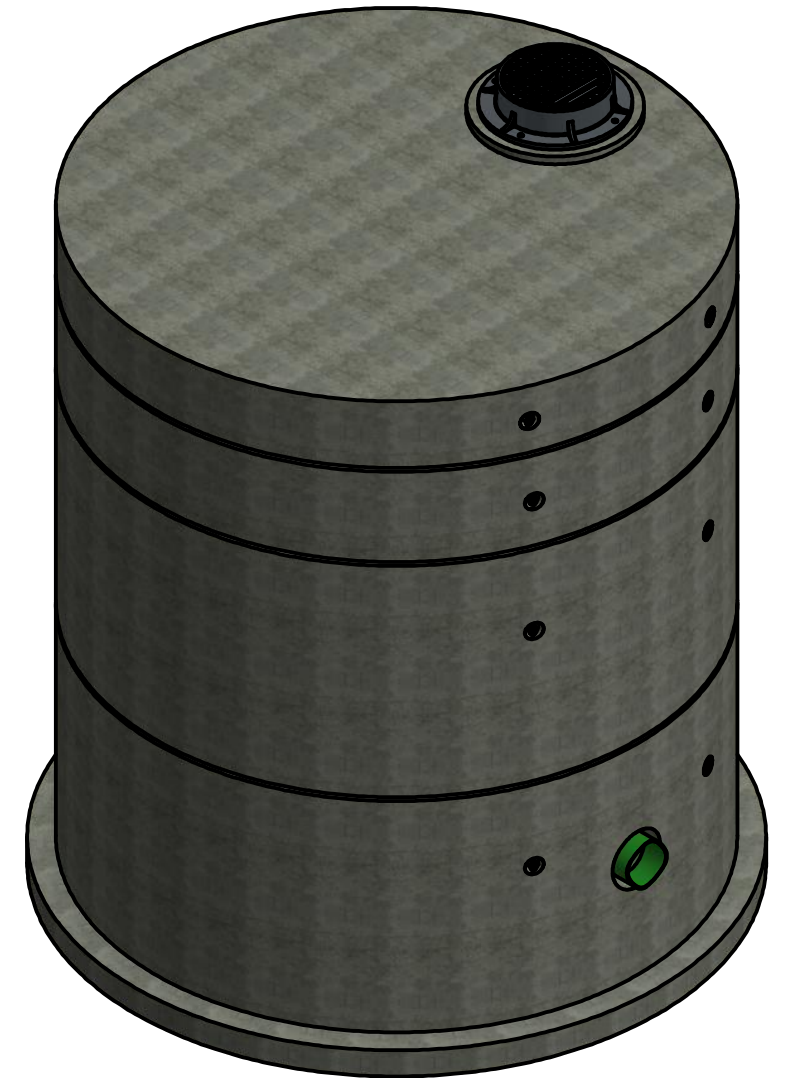

Isometric View

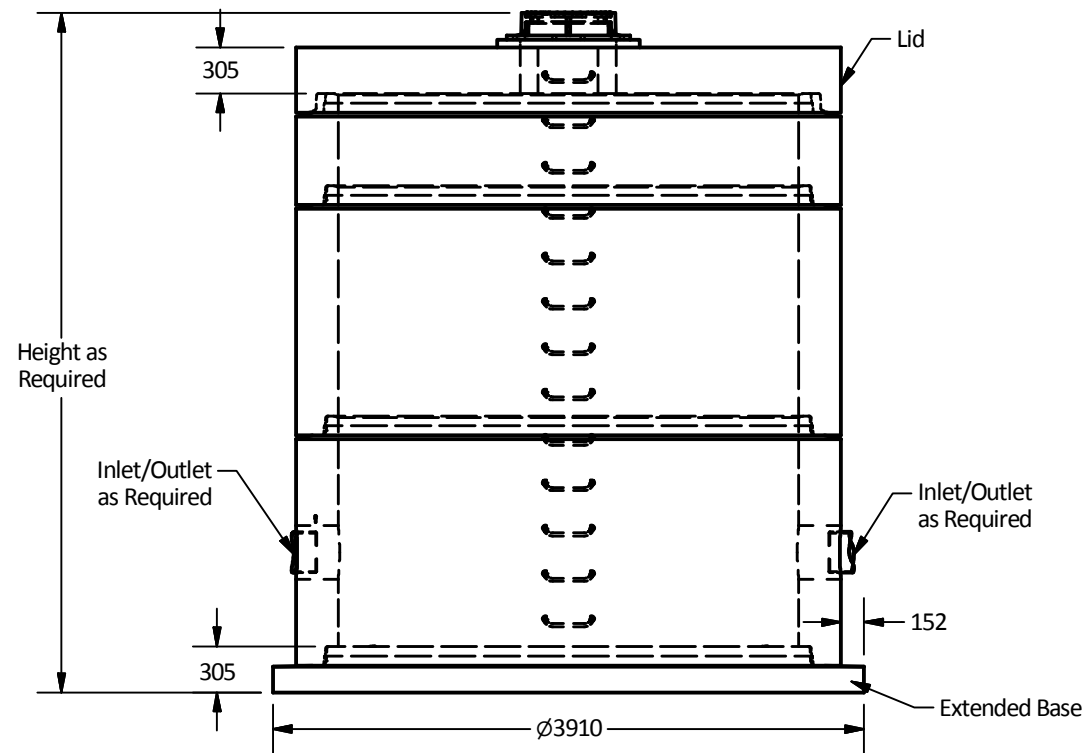

Elevation View

PART LIST			
ITEM	QTY	PART NUMBER	WEIGHT
1	As Required	3048 Manhole	7,232 kg/m.
2	1	MH 3048 Lid	7,715 kg.
3	1	MH 3048 EXTBase	7,780 kg.

Langley Concrete Group is a certified Q-Cast Plant, an American Concrete Pipe Association Third Party Certification for the manufacture of Pipe, Manhole, Box Culvert & Precast Items.



Quality Assurance of products manufactured by The Langley Concrete Group has been verified by the following third party certification programs



All Dimensions are in Millimeters. Unless otherwise Stated

Projection Method: THIRD ANGLE



This drawing is the property of the Langley Concrete Group of Companies. All information contained herein is confidential and may not be used in whole or in part without written permission from the owner

DESCRIPTION:

3050 Manhole with Extended Base

DRAWN BY: SR		JOB NO.
CHK BY: KS		DWG NO: MH-3050 Ext Base
DATE: Sep.20, 2018		
SCALE: 1:50		
SIZE: 11 x 17	REV.	SHEET 1 OF 1