

Plan View

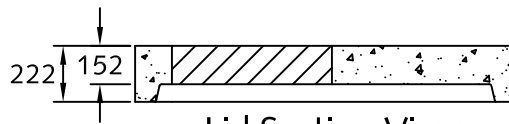

Lid Section View

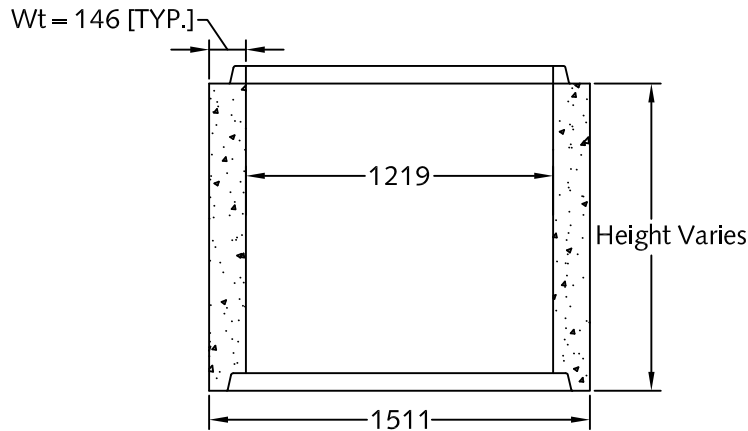

Section View

Note:

1. Manhole manufactured to ASTM C 478 specification.
2. Unit c/w 152 mm thick lid as shown [Optional].
3. Lid supplied w/ Ø635 or Ø762 mm access opening as shown.
4. Unit can be supplied w/ 152 mm thick optional base slab.
5. Unit supplied w/ lifting insert as required.
6. WWF minimum yield strength: 448 MPa.
7. Minimum rebar yield strength: 414 MPa.
8. Approximate mass: 1,550 kg/m.
9. Minimum concrete strength:
 - MH Barrel: 27.6 MPa.
 - Lid & Base: 35 MPa.
10. All reinforcing have minimum 25 mm of concrete cover.
11. All dimensions are in millimeters.



The LANGLEY CONCRETE Group of Companies

DESCRIPTION:

MH1200
Mortar Joint

www.langleyconcretegroup.com

DRAWN BY: KS ORIGIN: CHWK

CHK BY: N/A DWG NO: MH1200-MJ

DATE: FEB/02/2010 REV DATE:

SCALE: 1:30 1. MAY/10/2010

This drawing is the property of the Langley Concrete Group of Companies. All information contained herein is confidential and may not be used in whole or in part without written permission from the owner.