

PART LIST			
ITEM	QTY	PART NUMBER	WEIGHT
1	1	5213 Vault - Bottom	19,430 kg.
2	1	5213 Vault - Top	18,600 kg.

**Total of 56 Coalescing Media Units to be Supplied for this Order**

**Coalescing Plate has not been shown for clarification in plan view and side views**

**Notes:**

- 5213 Oil interceptor manufactured to meet AASHTO HS20/BCL-625 live loading.
- Concrete vault designed for the following earth covers:
  - Minimum: 0 m.
  - Maximum: 2.5 m.
- Unit supplied with opening for access as required.
- Unit supplied with rough cores for inlet/outlet as required.
- Unit supplied with ladder rungs as required.
- Unit supplied with lifting insert as required.
- Minimum rebar yield strength: 414 MPa.
- Minimum concrete strength: 35 MPa.
- Oil interceptor supplied w 102 mm thick concrete baffles as shown.
- Unit has a maximum 21,600 liter [ 21.6 m<sup>3</sup>] capacity.
- Unit design to:
  - Temp.: 0°C.
  - Oil S.G.: 0.85.
  - Influent oil = 100 mg/l.
  - Effluent oil <=15 mg/l.
  - Max flow: 77.9 l/s.
- PVC T required by design, supplied and installed by others in field.
- All dimensions are in millimeters.

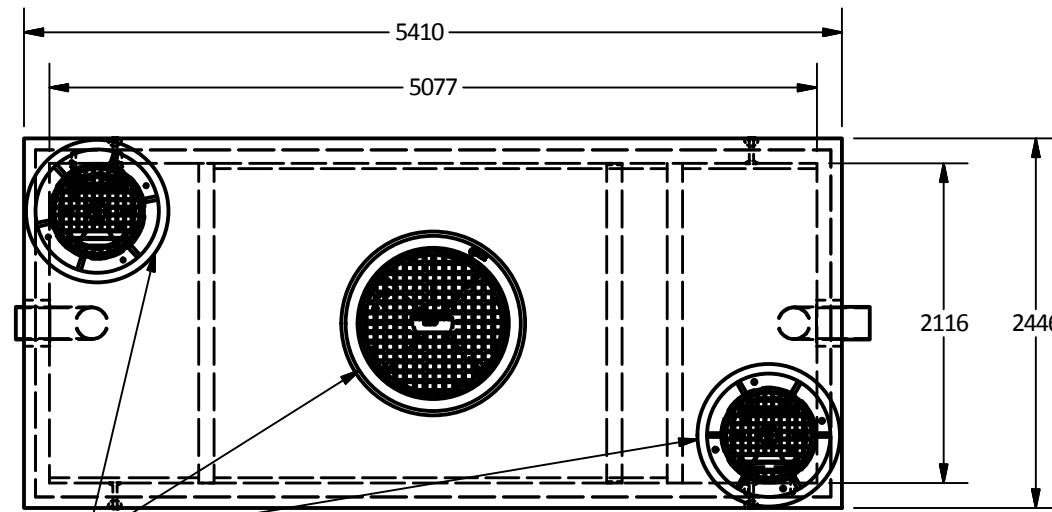

Access Opening Size and Location as Required

**Plan View**

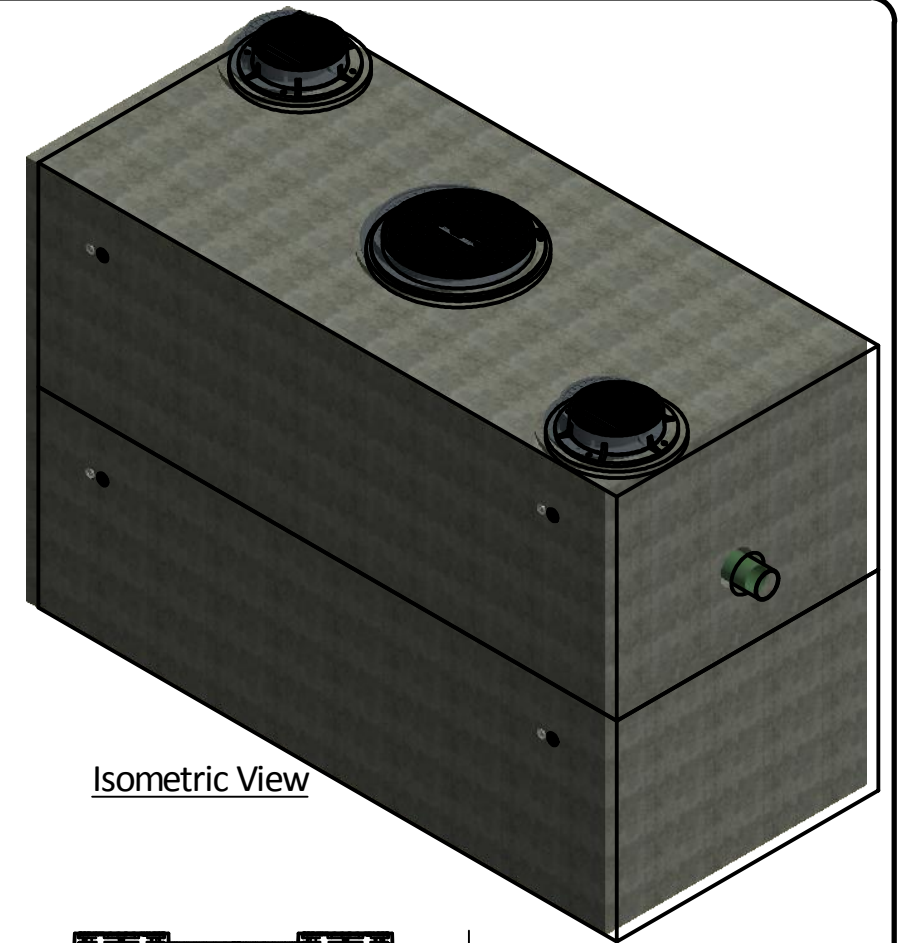

**Isometric View**

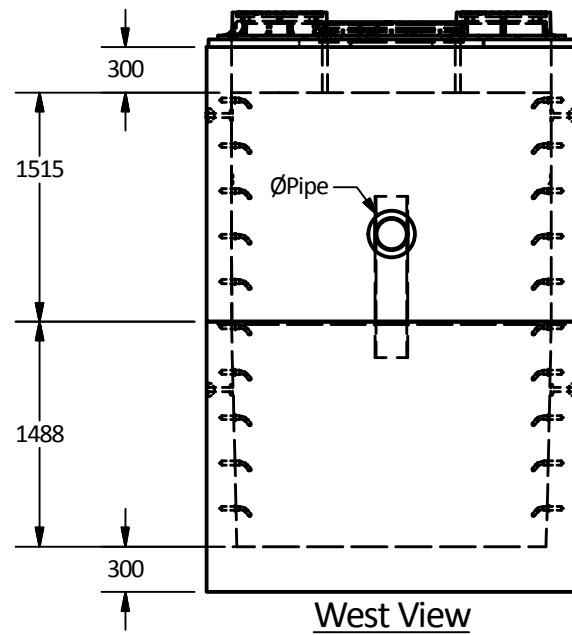

**West View**

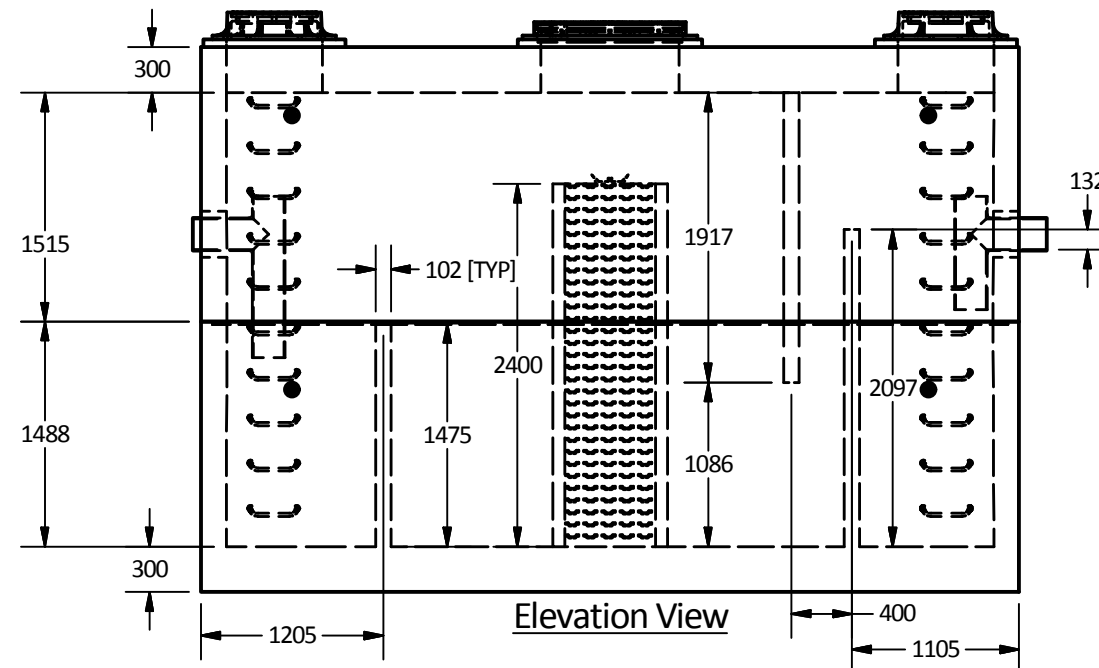

**Elevation View**

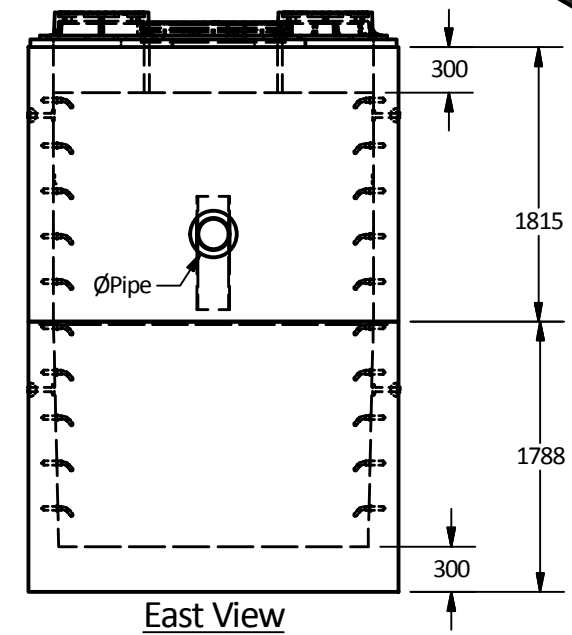

**East View**

Langley Concrete Group is a certified Q-Cast Plant, an American Concrete Pipe Association Third Party Certification for the manufacture of Pipe, Manhole, Box Culvert & Precast Items.



Quality Assurance of products manufactured by The Langley Concrete Group has been verified by the following third party certification programs



All Dimensions are in Millimeters. Unless otherwise Stated

Projection Method: THIRD ANGLE



LANGLEY (604) 533-1656  
VICTORIA (250) 478-9581  
CHILLIWACK 1-800 667-9600

This drawing is the property of the Langley Concrete Group of Companies. All information contained herein is confidential and may not be used in whole or in part without written permission from the owner

**DESCRIPTION:**

**5213 Coalescing Plate Oil Interceptor  
8mm Spacing**

DRAWN BY: SR		JOB NO.
CHK BY: KS		DWG NO: 5213-COI-8
DATE: Oct.03, 2018		
SCALE: 1:50		
SIZE 11 x 17	REV.	SHEET 1 OF 1