

PART LIST			
ITEM	QTY	PART NUMBER	WEIGHT
1	1	Type I Vault	1,680 kg.
2	1	Type I Lid	600 kg.

- Notes:
- Type I Reinforced concrete vault is built as shown.
 - Unit designed to withstand AASHTO HS20 / BCL-625 live loading.
 - Concrete vault designed for the following earth covers:
 - Minimum: 0 m.
 - Maximum: 2.5 m.
 - Unit risers available in heights: 305, 450 etc to 1050mm maximum.
 - Unit supplied with lifting inserts as required.
 - Unit supplied with opening for access as required.
 - Design can be modified for specific sites, please contact LCG sales office.
 - Unit to have 4-Ø51 mm vent holes as shown.
 - Oil interceptor supplied with 12 gauge galvanized baffles as shown.
 - Unit has a maximum 595 liter [0.595 m³] capacity.
 - Minimum rebar yield strength: 414 MPa.
 - Minimum concrete strength: 35 MPa.
 - PVC T required by design, supplied and installed by others in field.
 - All dimensions are in millimeters.

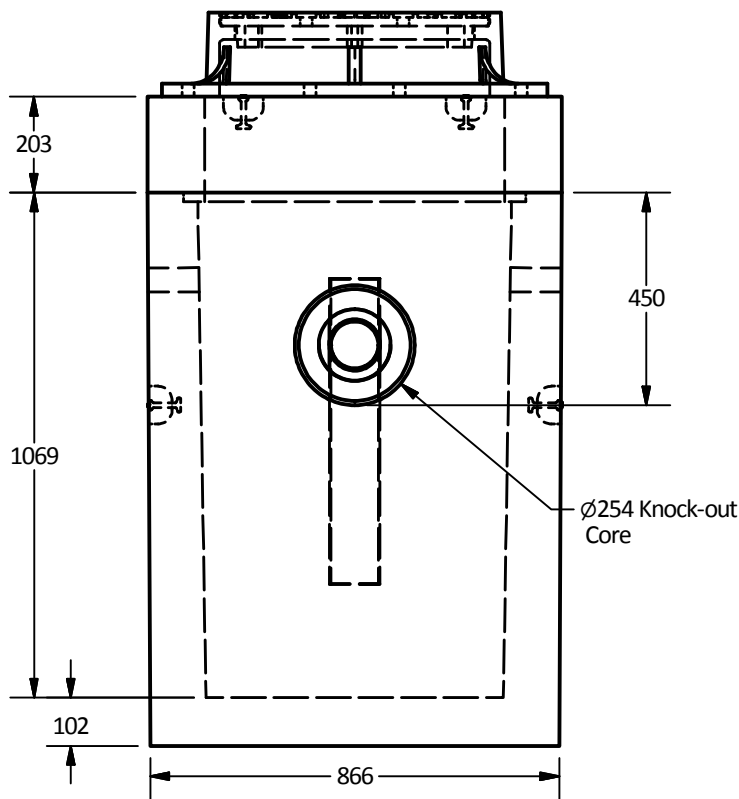

East View

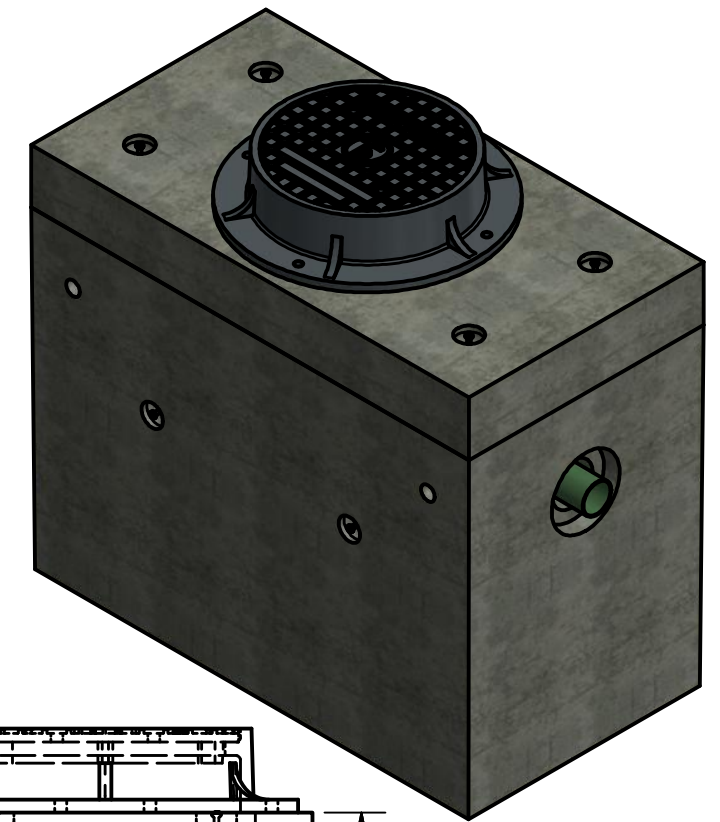
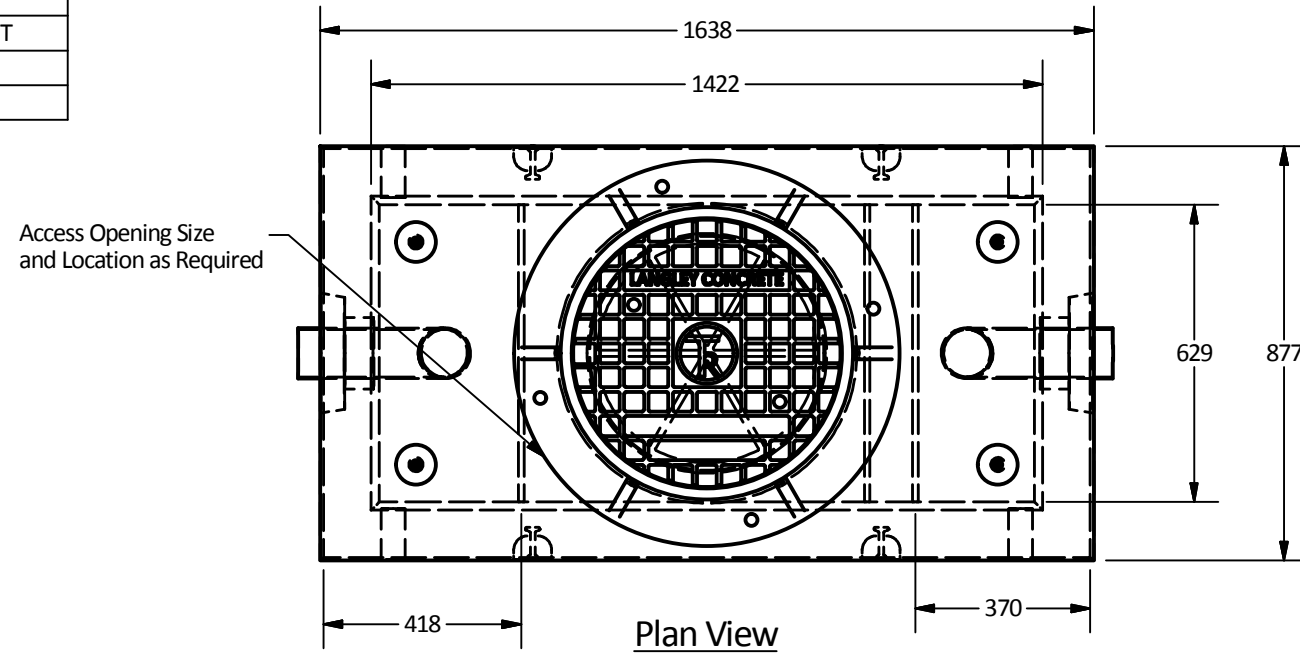
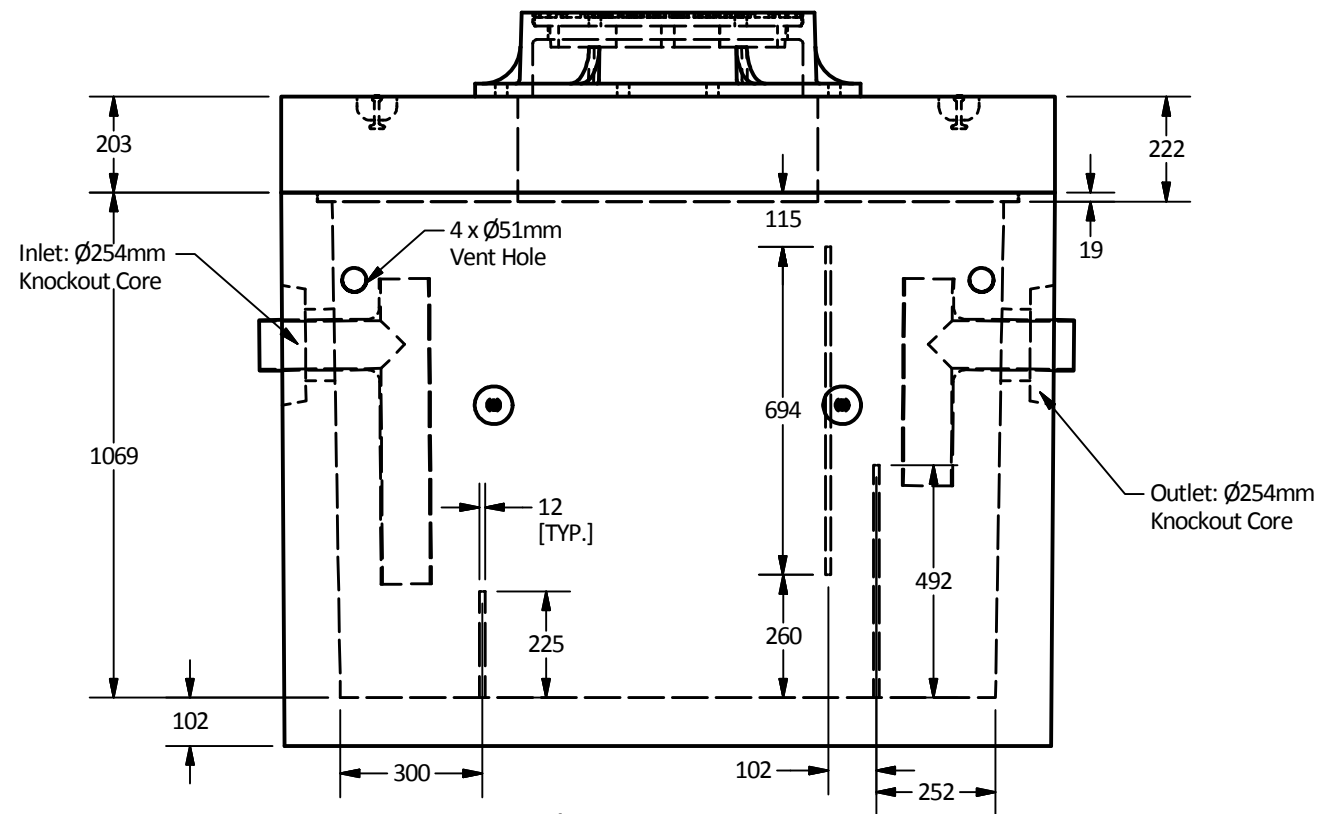

Elevation View

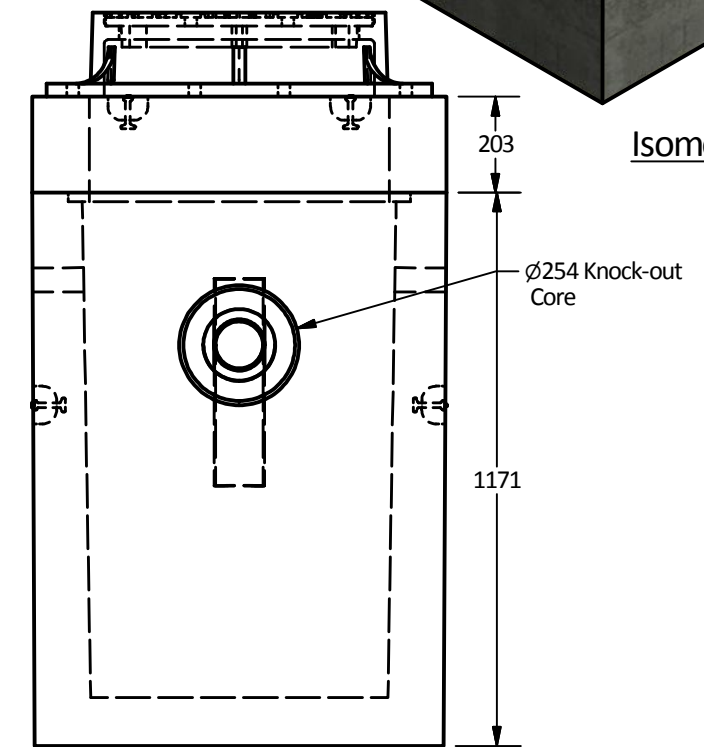

West View

Isometric View

Langley Concrete Group is a certified Q-Cast Plant, an American Concrete Pipe Association Third Party Certification for the manufacture of Pipe, Manhole, Box Culvert & Precast Items.



Quality Assurance of products manufactured by The Langley Concrete Group has been verified by the following third party certification programs



All Dimensions are in Millimeters. Unless otherwise Stated

Projection Method: THIRD ANGLE



LANGLEY (604) 533-1656
VICTORIA (250) 478-9581
CHILLIWACK 1-800 667-9600

This drawing is the property of the Langley Concrete Group of Companies. All information contained herein is confidential and may not be used in whole or in part without written permission from the owner

DESCRIPTION:

Type I Oil Interceptor
API Style

DRAWN BY: SR	JOB NO.
CHK BY: KS	DWG NO: TYPE I -API
DATE: Oct.02, 2018	
SCALE: 1:16	
SIZE 11 x 17	REV.
	SHEET 1 OF 1