

PART LIST			
ITEM	QTY	PART NUMBER	WEIGHT
1	1	Type II Vault	4,520 kg.
2	1	Type II Lid	1,450 kg.

Notes:

- Type II Oil interceptor manufactured to meet AASHTO HS20/BCL-625 live loading.
- Lid designed to withstand AASHTO HS20 / BCL-625 live loading.
- Concrete vault designed for the following earth covers:
 - Minimum: 0 m.
 - Maximum: 2.5 m.
- Unit supplied with 700mm x 450mm square knockout for inlet/outlet as shown.
- Unit supplied with lifting inserts as required.
- Lid supplied with opening for access as required.
- Unit supplied w/ 4-Ø76 mm vent holes as shown.
- Oil interceptor c/w 12mm gauge galvanized baffles as shown.
- Unit has a maximum 2,000 liter [2.0 m³] capacity.
- Unit risers available in heights:
 - 305, 450 etc to 1500mm maximum.
- Design can be modified for specific sites, please contact LCG sales office.
- Minimum rebar yield strength: 414 MPa.
- Minimum concrete strength: 35 MPa.
- PVC T required by design, supplied and installed by others in field.
- All dimensions are in millimeters.

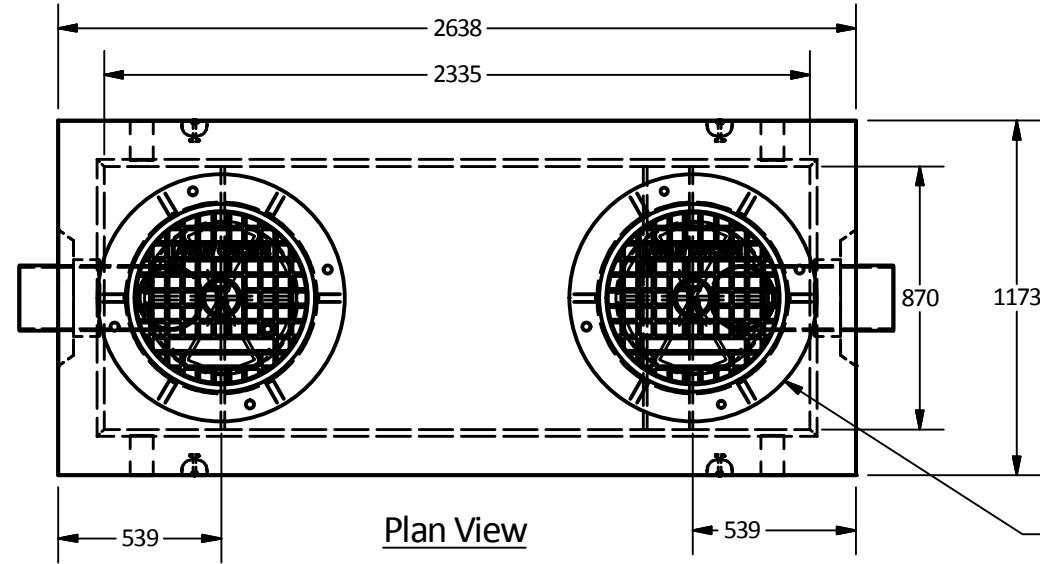

Access Opening Size and Location as Required

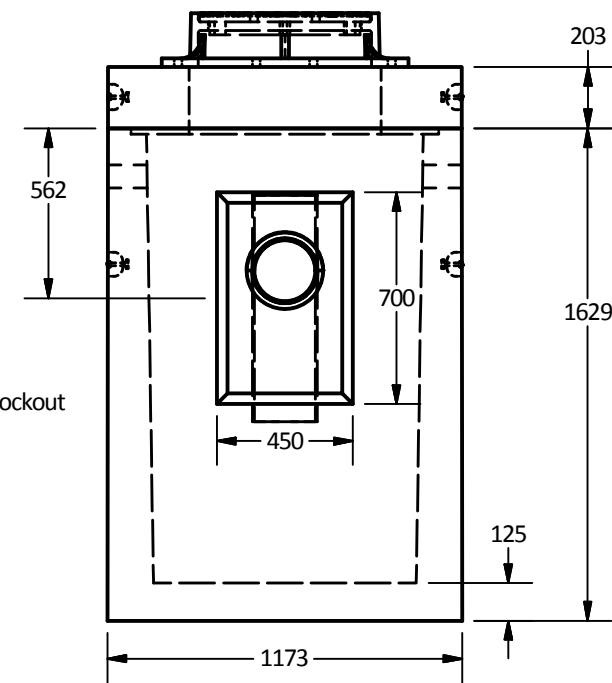
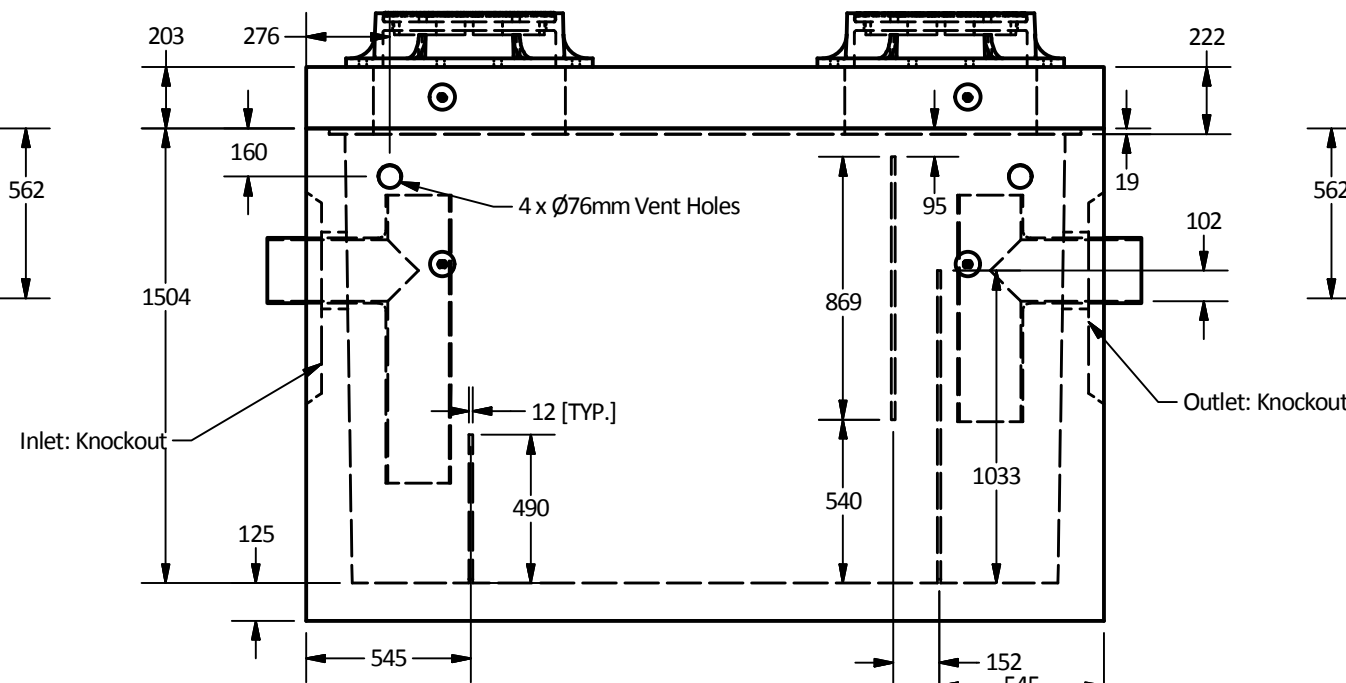
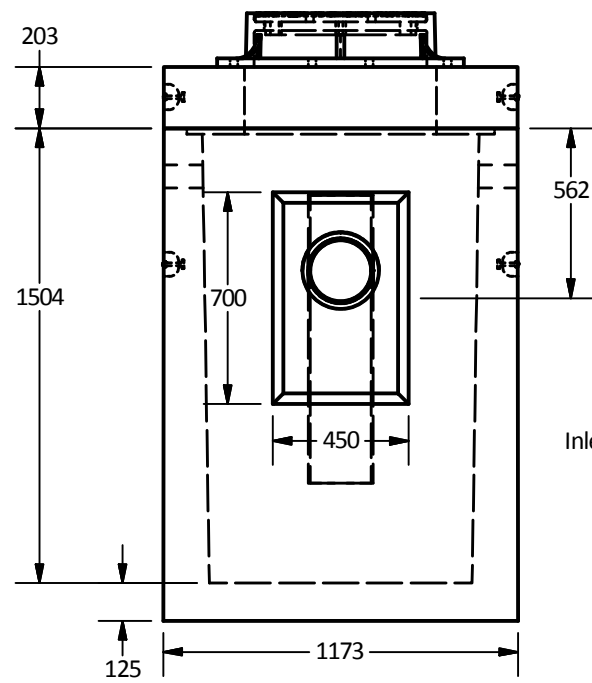
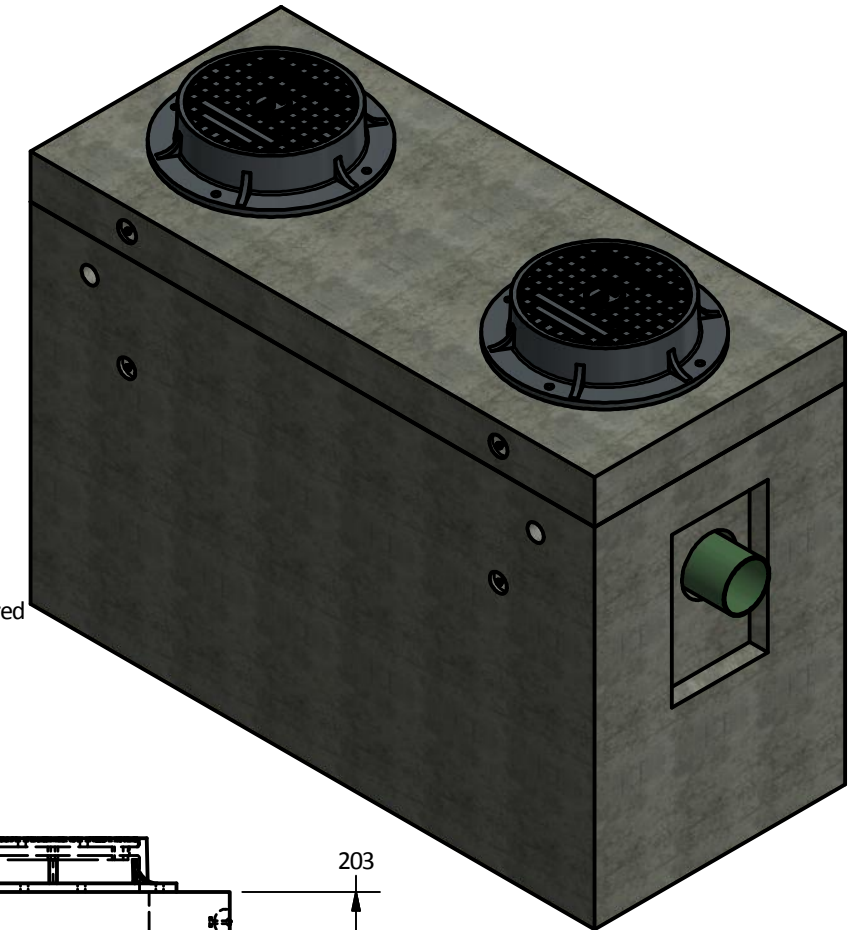

Langley Concrete Group is a certified Q-Cast Plant, an American Concrete Pipe Association Third Party Certification for the manufacture of Pipe, Manhole, Box Culvert & Precast Items.



Quality Assurance of products manufactured by The Langley Concrete Group has been verified by the following third party certification programs



All Dimensions are in Millimeters. Unless otherwise Stated

Projection Method: THIRD ANGLE



LANGLEY (604) 533-1656
VICTORIA (250) 478-9581
CHILLIWACK 1-800 667-9600

This drawing is the property of the Langley Concrete Group of Companies. All information contained herein is confidential and may not be used in whole or in part without written permission from the owner

DESCRIPTION:

Type II Oil Interceptor [API Style]

DRAWN BY: SR	JOB NO.
CHK BY: KS	DWG NO: TYPE II-API
DATE: Aug.14, 2018	
SCALE: 1:25	
SIZE 11 x 17	REV.
	SHEET 1 OF 1