

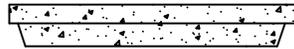

Non-H2O 'Light Lid'

Approximate Weight: 65 kg

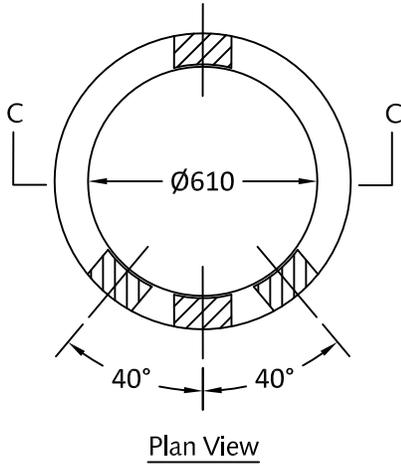

Concrete 'Double Lid'

Approximate Weight: 105 kg

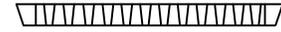
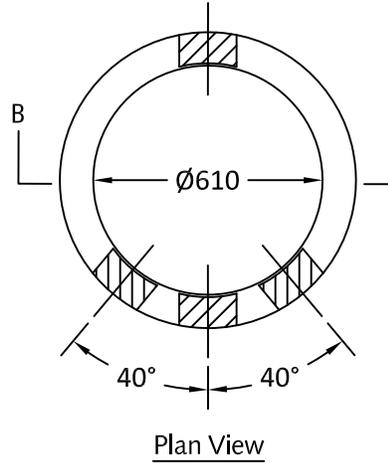

TR22B Cast Iron H2O Grate

Approximate Weight: 63 kg

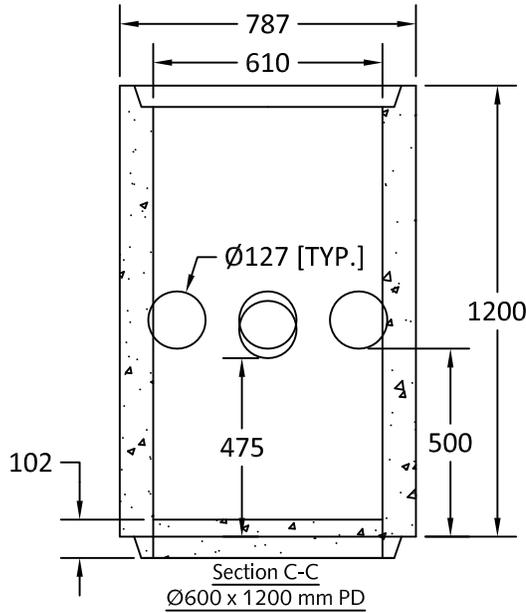
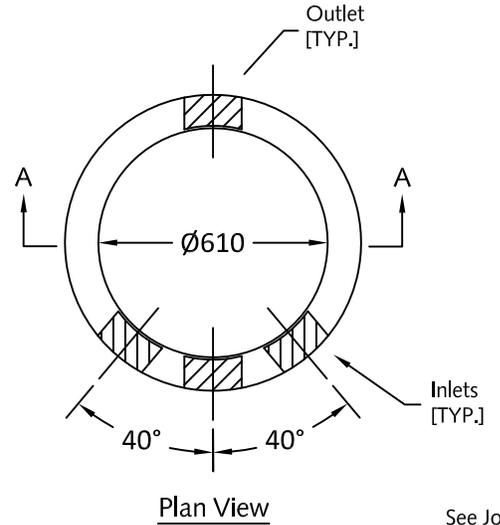

Approximate weight:

- Ø600 x 1200 mm: 585 kg.
- w/ Base: 660 kg

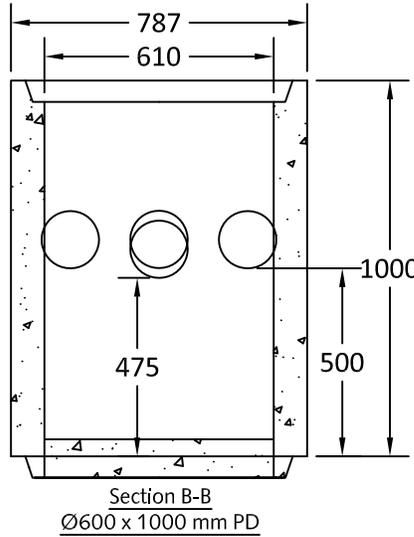

Approximate weight:

- Ø600 x 1000 mm: 485 kg.
- w/ Base: 560 kg

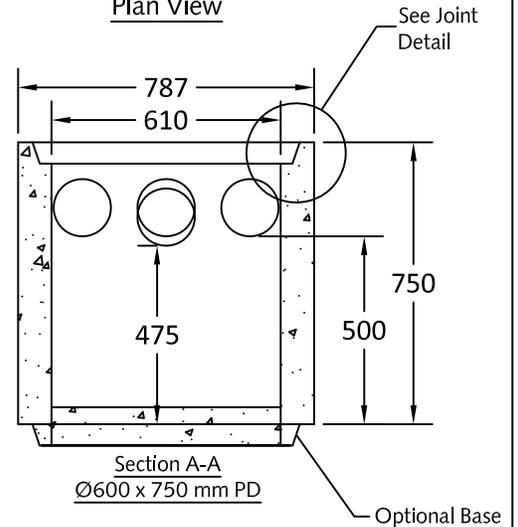

Approximate weight:

- Ø600 x 750 mm: 365 kg.
- w/ Base: 445 kg

Notes:

1. Ø600 x 750, Ø600 x 1000 & Ø600 x 1200 mm Perimeter drains as shown.
2. Perimeter Drains are not intended for use in vehicular traffic areas.
3. Available with 100mm thick cast in base.
4. Light lids, slotted are not rated for vehicular traffic.
5. Lids c/w recessed handles for lifting.
6. Unit c/w rough cores for drainage pipe as shown.
7. Risers available: 150, 300, 450, 600, 750 & 1200 mm heights.
8. Minimum concrete strength: 27.6 MPa.
9. All dimensions are in millimeters.

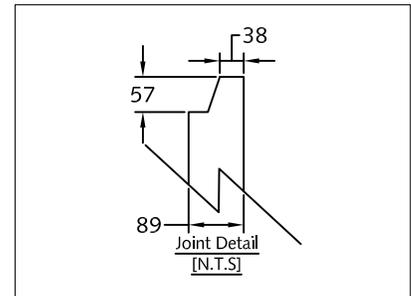

The LANGLEY CONCRETE Group of Companies
www.langleyconcretegroup.com

DESCRIPTION:

Ø600 mm-Perimeter Drains

DRAWN BY: KS

JOB NO.:N/A

CHK BY: JAO/TM

DWG NO: PD-2

DATE: April 21, 2018

REV. BY: CC
Aug. 10, 2018

SCALE: 1:20

This drawing is the property of the Langley Concrete Group of Companies. All information contained herein is confidential and may not be used in whole or in part without written permission from the owner.

LCG Products are held to the governing ASTM, and CSA specification & tolerances.

LANGLEY (604) 533-1656 VICTORIA (250) 478-9581 CHILLIWACK 1-800 667-9600