

Double Lid

Approximate Weight: 195 kg

Light Lid

Approximate Weight: 85 kg

See Joint Detail

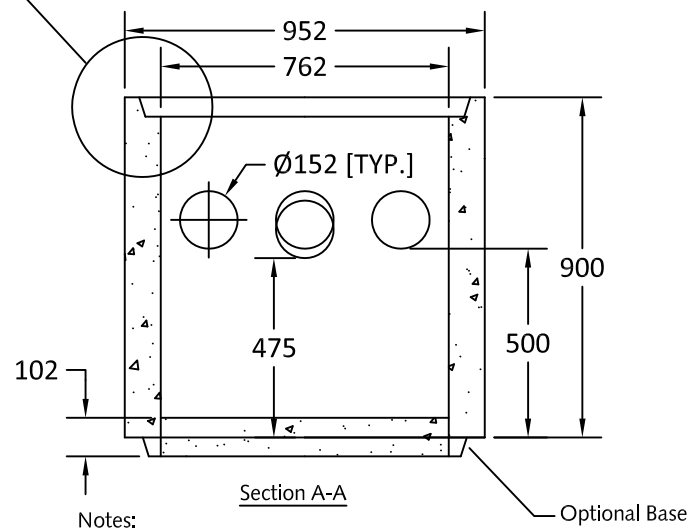

Notes:

1. Ø750 x 900 mm Perimeter drains as shown.
2. Perimeter Drains are not intended for use in vehicular traffic areas.
3. Available with 100 mm thick cast in base.
4. Light lids, slotted are not rated for vehicular traffic.
5. Lids c/w recessed handles for lifting.
6. Unit c/w rough cores for drainage pipe as shown.
7. Risers available: 300, 450, 600 & 900 mm heights.
8. Approximate weight:
 - Ø750 x 900 mm: 575 kg.
 - w/ Base: 690 kg.
9. Minimum concrete strength: 27.6 MPa.
10. All dimensions are in millimeters.

Quality Assurance of products manufactured by The Langley Concrete Group has been verified by the following third party certification programs:

THE Langley CONCRETE GROUP
The LANGLEY CONCRETE Group of Companies
www.langleyconcretegroup.com

DESCRIPTION:
Ø750x900 mm Perimeter Drains

LANGLEY (604) 533-1656 VICTORIA (250) 478-9581 CHILLIWACK 1-800 667-9600

DRAWN BY: KS	JOB NO.: N/A
CHK BY: JAO/TM	DWG NO: PD-3
DATE: Apr. 22, 2010	REV. BY: CC
SCALE: 1:20	Aug. 13, 2018
<small>This drawing is the property of the Langley Concrete Group of Companies. All information contained herein is confidential and may not be used in whole or in part without written permission from the owner.</small>	LCG Products are held to the governing ASTM, and CSA specification & tolerances.