

Inner Light Lid

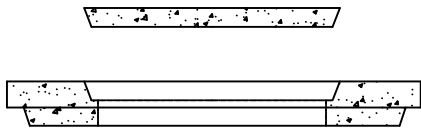

Inspection Lid w/ 600 mm Inner

Approximate Weight: 225 kg

Light Lid

Approximate Weight: 95 kg

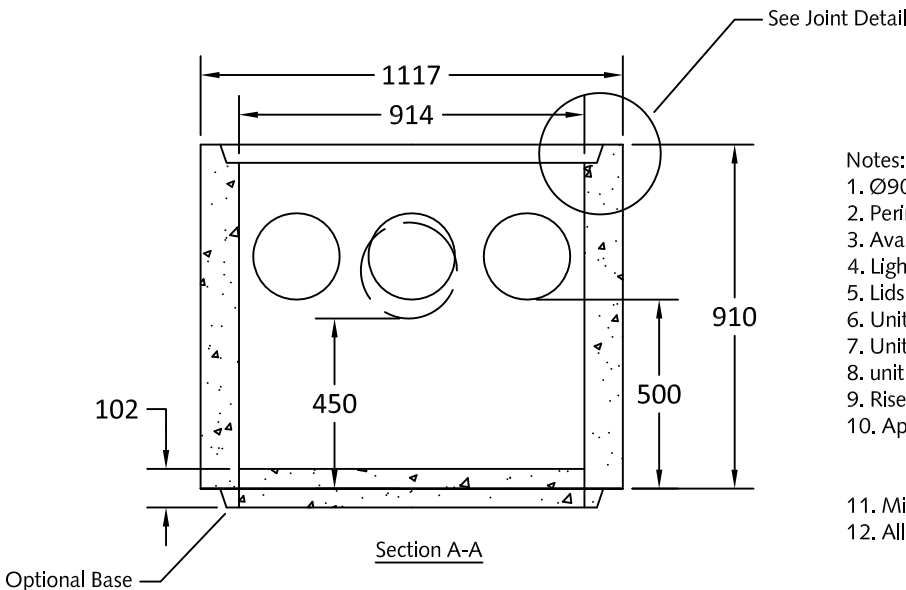
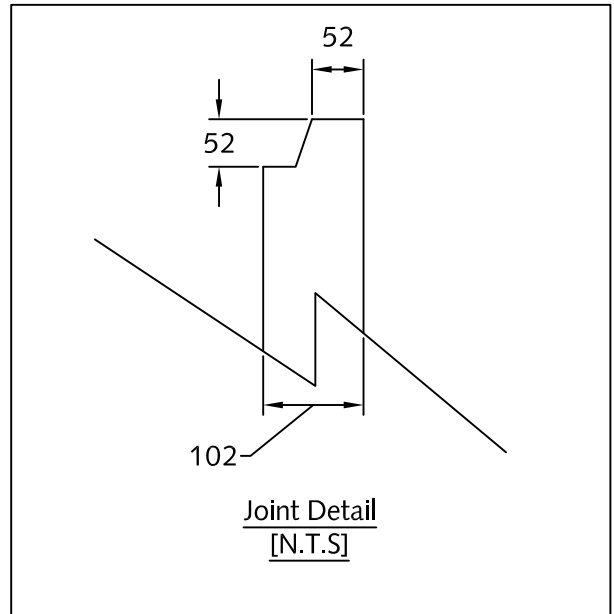
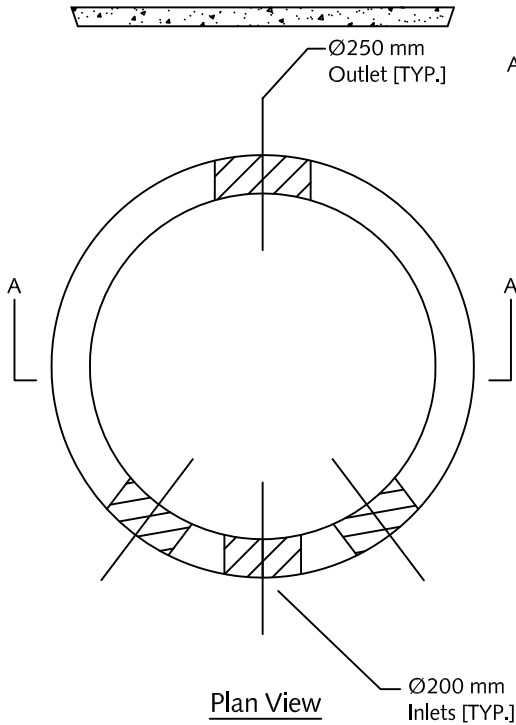

Notes:

1. Ø900 x 900 mm Perimeter drains as shown.
2. Perimeter Drains are not intended for use in vehicular traffic areas.
3. Available with 100 mm thick cast in base.
4. Light lids are not rated for vehicular traffic.
5. Lids c/w recessed handles for lifting.
6. Unit c/w rough cores for drainage pipe as shown.
7. Unit c/w optional ladder rungs.
8. unit c/w lifting inserts as required.
9. Risers available: 300, 450, 600 & 900 mm heights.
10. Approximate weight:
 - Ø900 x 900 mm: 785 kg.
 - w/ Base: 955 kg.
11. Minimum concrete strength: 27.6 MPa.
12. All dimensions are in millimeters.

<p>Quality Assurance of products manufactured by The Langley Concrete Group has been verified by the following third party certification programs:</p>	<p>The LANGLEY CONCRETE Group of Companies www.langleyconcretegroup.com</p>	<p>DESCRIPTION:</p> <p>Ø900 x 900 mm Perimeter Drains</p>	DRAWN BY: KS	JOB NO.:N/A
			CHK BY: JAO/TM	DWG NO: PD-4
			DATE: Apr. 22, 2010	REV. BY: CC
			SCALE: 1:20	Aug. 10, 2018
			<p>This drawing is the property of the Langley Concrete Group of Companies. All information contained herein is confidential and may not be used in whole or in part without written permission from the owner.</p>	
<p>LANGLEY (604) 533-1656 VICTORIA (250) 478-9581 CHILLIWACK 1-800 667-9600</p>			<p>LCG Products are held to the governing ASTM, and CSA specification & tolerances.</p>	