

Section View  
Design for HS20 Loadings

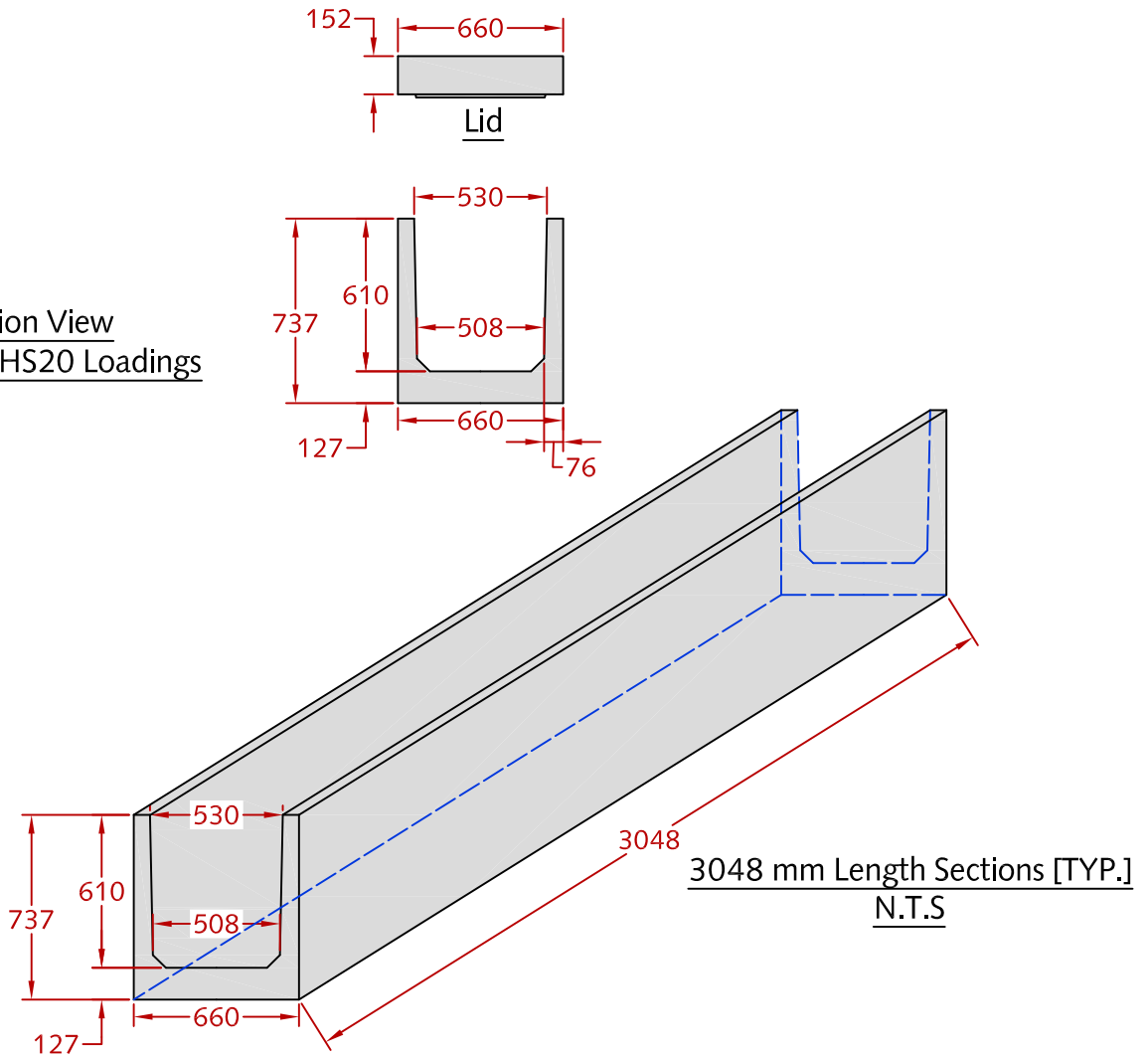

Notes:

1. 3048 x 508 x 610 mm Precast Cable Trench as shown.
2. Unit designed to withstand HS20 live loading as required.
3. Unit supplied w/ Starcon style lifting inserts as required.
4. Unit supplied with 3048 x 660 x 152 mm Reinforced Concrete Lid, designed to withstand HS20 live loading.
5. Minimum concrete strength: 35 MPa.
6. Welded wire mesh min. yield strength: 448 MPa.
7. Minimum rebar yield strength: 414 MPa.
8. All reinforcing to have minimum of 25.4 mm concrete cover [TYP.].
9. Approximate mass:
  - Trench Box: 435 kg/m.
  - Trench Box weight/3.048 lm: 1,325 kg.
  - Lid [3048 L x 660 W x 152 T mm]: 775 kg.
10. All dimensions are in millimeters.
11. Installation and Back Fill as per LCG's Trench Box Catalogue.



Quality Assurance of products manufactured by The Langley Concrete Group has been verified by the following third party certification programs:



DESCRIPTION:

3048 x 508 x 610 mm  
Precast Cable Trench  
Designed for HS20 Live Loading

DRAWN BY:	KS	DWG NO:PCT TYPE A
CHK BY:	JDB/SW	REV DATE:JUNE/17/2013
DATE:	APR/19/2011	
SCALE:	1:30	

This drawing is the property of the Langley Concrete Group of Companies.  
All information contained herein is confidential and may not be used in whole or in part without written permission from the owner.

LCG Products are held to the governing ASTM, and CSA specification & tolerances.