

PART LIST			
ITEM	QTY	PART NUMBER	WEIGHT
1	1	1.8 x 1.8 Vault	5,300 kg.
2	1	1.8 x 1.8 Lid	3,300 kg.

- Notes:
- 1.8 x 1.8 vault is built as shown.
  - Unit designed to withstand AASHTO HS20/BCL-625 live load.
  - Concrete vault designed for following earth cover:
    - Minimum: 0m
    - Maximum: 2.5m.
  - Unit supplied with lifting insert as required.
  - Lid supplied with opening for access as required.
  - Unit can be supplied with sump as required.
  - Minimum rebar yield strength: 414 MPa.
  - Minimum concrete strength: 30 MPa.
  - Vault interior can be supplied with white paint for improved visibility/cleanliness and damproofed exterior using CS-55 or approved equivalent.
  - All dimensions are in millimeters.

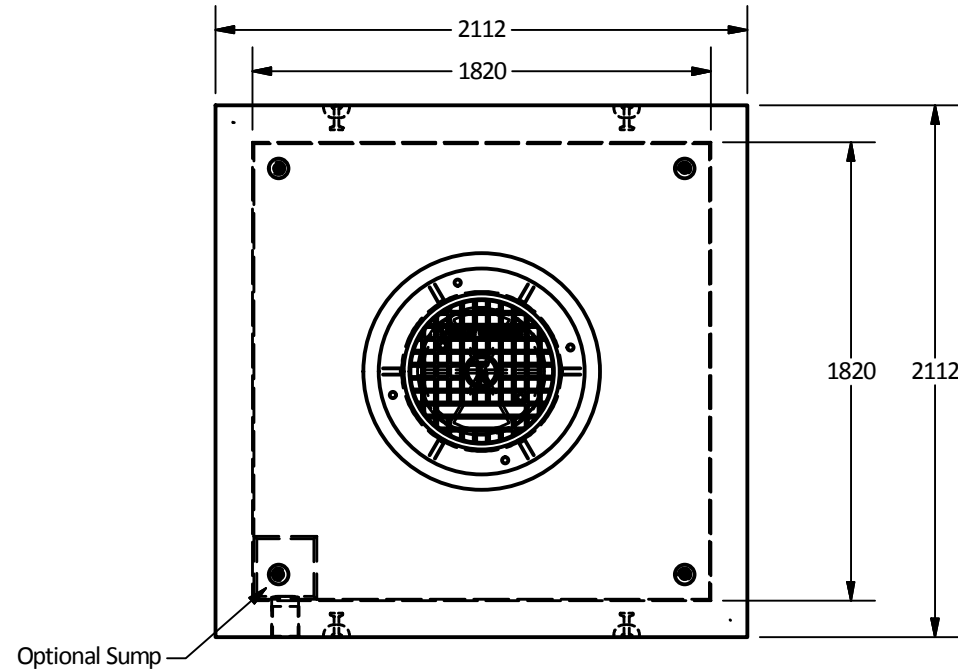

Plan View

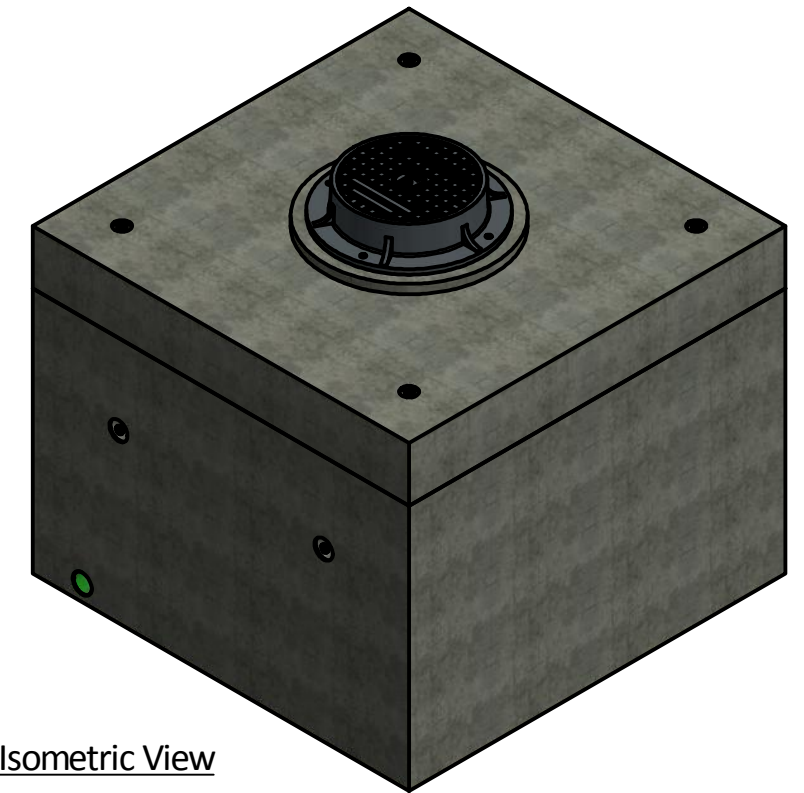

Isometric View

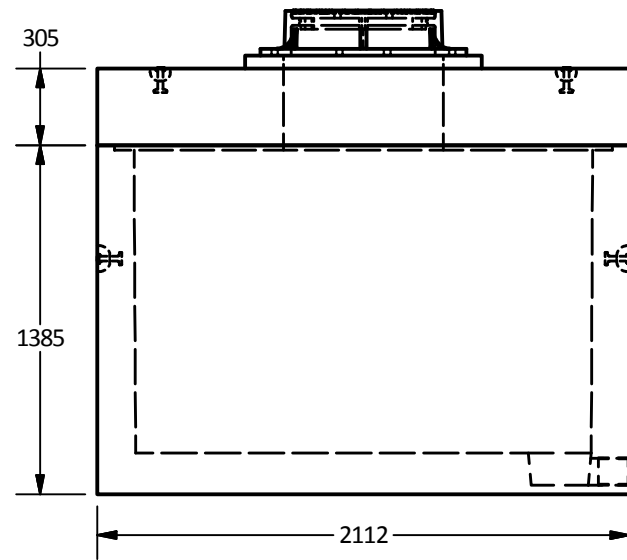

West View

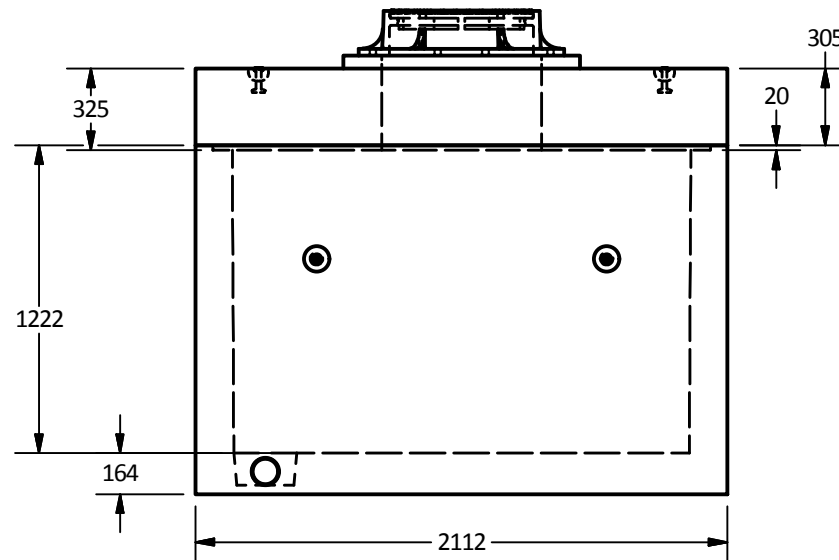

Elevation View

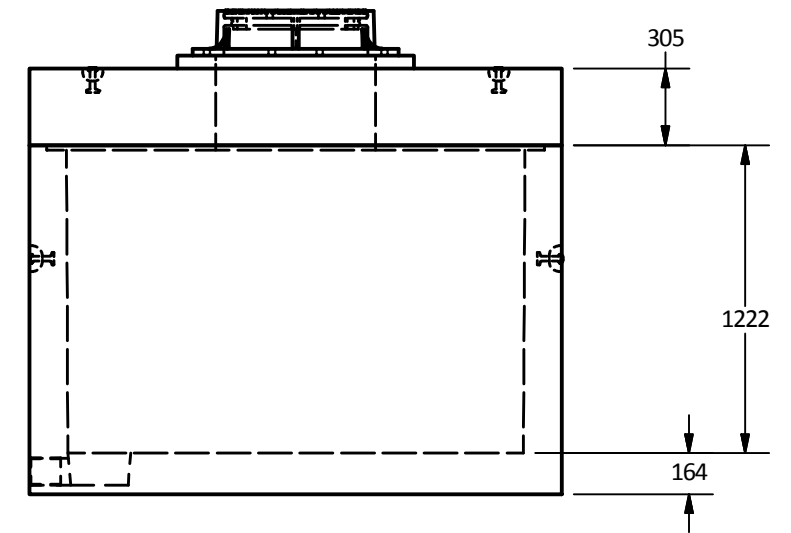

East View

Langley Concrete Group is a certified Q-Cast Plant, an American Concrete Pipe Association Third Party Certification for the manufacture of Pipe, Manhole, Box Culvert & Precast Items.



Quality Assurance of products manufactured by The Langley Concrete Group has been verified by the following third party certification programs



All Dimensions are in Millimeters. Unless otherwise Stated

Projection Method: THIRD ANGLE



LANGLEY (604) 533-1656  
VICTORIA (250) 478-9581  
CHILLIWACK 1-800 667-9600

This drawing is the property of the Langley Concrete Group of Companies. All information contained herein is confidential and may not be used in whole or in part without written permission from the owner

DESCRIPTION:

Vault 1.8 x 1.8

DRAWN BY: SR

JOB NO.

CHK BY: KS

DWG NO: V 1.8 x 1.8-1.0

DATE: Aug.10, 2018

SCALE: 1:30

SIZE: 11 x 17

REV.

SHEET 1 OF 1