

- GENERAL NOTES:**
1. ALL DIMENSIONS INDICATED ARE IN INCHES (MILLIMETERS) UNLESS OTHERWISE SPECIFIED.
 2. JELLYFISH STRUCTURE INLET AND OUTLET PIPE SIZE AND ORIENTATION SHOWN FOR INFORMATIONAL PURPOSES ONLY.
 3. UNLESS OTHERWISE NOTED, BYPASS INFRASTRUCTURE, SUCH AS ALL UPSTREAM DIVERSION STRUCTURES, CONNECTING STRUCTURES, OR PIPE CONDUITS CONNECTING TO COMPLETE THE JELLYFISH SYSTEM SHALL BE PROVIDED AND ADDRESSED SEPARATELY.
 4. DRAWING FOR INFORMATION PURPOSES ONLY. REFER TO ENGINEER'S SITE/UTILITY PLAN FOR STRUCTURE ORIENTATION.

- JELLYFISH STRUCTURE & DESIGN NOTES:**
1. CASTINGS OR DOORS OF THE JELLYFISH MANHOLE STRUCTURE TO EXTEND TO DESIGN FINISH GRADE. DEPTHS IN EXCESS OF 3.65 M (12') MAY REQUIRE THE DESIGN AND INSTALLATION OF INTERMEDIATE SAFETY GRATES OR OTHER STRUCTURAL ELEMENTS.
 2. CASTINGS AND GRADE RINGS, OR DOORS AND DOOR RISERS, OR BOTH, SHALL BE GROUTED FOR WATERTIGHTNESS.
 3. STRUCTURE SHALL MEET AASHTO HS-20, ASSUMING EARTH COVER OF 0' - 3', AND GROUNDWATER ELEVATION AT, OR BELOW, THE OUTLET PIPE INVERT ELEVATION. ENGINEER OF RECORD TO CONFIRM ACTUAL GROUNDWATER ELEVATION. CASTINGS SHALL MEET AASHTO M306 LOAD RATING AND BE CAST WITH THE IMBRIUM LOGO.
 4. ALL STRUCTURAL SECTIONS AND PARTS TO MEET OR EXCEED ASTM C-478, ASTM C-443, AND ASTM D-4097 CORRESPONDING TO AASHTO SPECIFICATIONS, AND ANY OTHER SITE OR LOCAL STANDARDS.
 5. CONCRETE RISER SECTIONS FROM BOTTOM TO TOP WILL BE ADDED AS REQUIRED INCLUDING TRANSITION PIECES TO SMALLER DIAMETER RISERS FOR SURFACE ACCESSES WHERE WARRANTED BY SERVICING DEPTH.
 6. IF MINIMUM DEPTH FROM TOP OF CARTRIDGE DECK TO BOTTOM OF STRUCTURAL TOP SLAB CANNOT BE ACHIEVED DUE TO PIPING INVERT ELEVATIONS OR OTHER SITE CONSTRAINTS. ALTERNATIVE HATCH CONFIGURATIONS MAY BE AVAILABLE. HATCH DOORS SHOULD BE SIZED TO PROVIDE FULL ACCESS ABOVE THE CARTRIDGES TO ACCOMMODATE MAINTENANCE.
 7. STEPS TO BE APPROXIMATELY 330 MM (13") APART AND DIMENSIONS MUST MEET LOCAL STANDARDS. STEPS MUST BE INSTALLED AFTER CARTRIDGE DECK IS IN PLACE.
 8. CONFIGURATION OF INLET AND OUTLET PIPE CAN VARY TO MEET SITE'S NEEDS.
 9. IT IS THE RESPONSIBILITY OF OTHERS TO PROPERLY PROTECT THE TREATMENT DEVICE, AND KEEP THE DEVICE OFFLINE DURING CONSTRUCTION. FILTER CARTRIDGES SHALL NOT BE INSTALLED UNTIL THE PROJECT SITE IS CLEAN AND FREE OF DEBRIS, BY OTHERS. THE PROJECT SITE INCLUDES ANY SURFACE THAT CONTRIBUTES STORM DRAINAGE TO THE TREATMENT DEVICE. CARTRIDGES SHALL BE FURNISHED NEW, AT THE TIME OF FINAL ACCEPTANCE.
 10. THIS DRAWING MUST BE VIEWED IN CONJUNCTION WITH THE STANDARD JELLYFISH SPECIFICATION, AND STORMWATER QUALITY FILTER TREATMENT JELLYFISH DOCUMENTS.

- INSTALLATION NOTES**
- A. ANY SUB-BASE, BACKFILL DEPTH, AND/OR ANTI-FLOTATION PROVISIONS ARE SITE-SPECIFIC DESIGN CONSIDERATIONS AND SHALL BE SPECIFIED BY ENGINEER OF RECORD.
 - B. CONTRACTOR TO PROVIDE EQUIPMENT WITH SUFFICIENT LIFTING AND REACH CAPACITY TO LIFT AND SET THE STRUCTURE (LIFTING CLUTCHES PROVIDED)
 - C. CONTRACTOR WILL INSTALL AND LEVEL THE STRUCTURE, SEALING THE JOINTS, LINE ENTRY AND EXIT POINTS (NON-SHRINK GROUT WITH APPROVED WATERSTOP OR FLEXIBLE BOOT)
 - D. CONTRACTOR TO TAKE APPROPRIATE MEASURES TO PROTECT CARTRIDGES FROM CONSTRUCTION-RELATED EROSION RUNOFF.
 - E. CARTRIDGE INSTALLATION, BY IMBRIUM, SHALL OCCUR ONLY AFTER SITE HAS BEEN STABILIZED AND THE JELLYFISH UNIT IS CLEAN AND FREE OF DEBRIS. CONTACT IMBRIUM TO COORDINATE CARTRIDGE INSTALLATION WITH SITE STABILIZATION.
 - F. CONTRACTOR TO REMOVE THE TRANSFER HOLE COVERS WHEN THE SYSTEM IS BROUGHT ONLINE AND THE SITE IS STABILIZED.

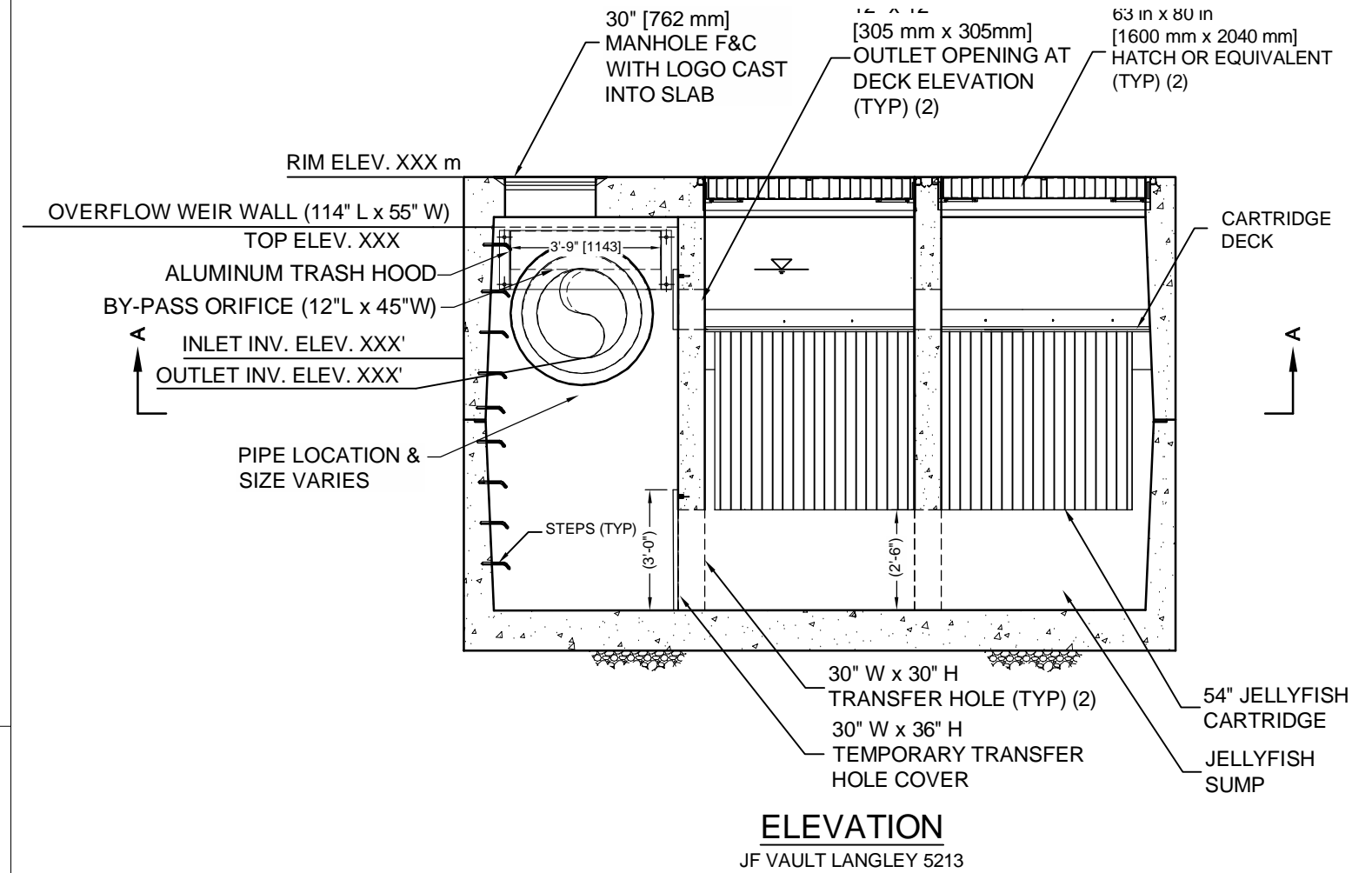
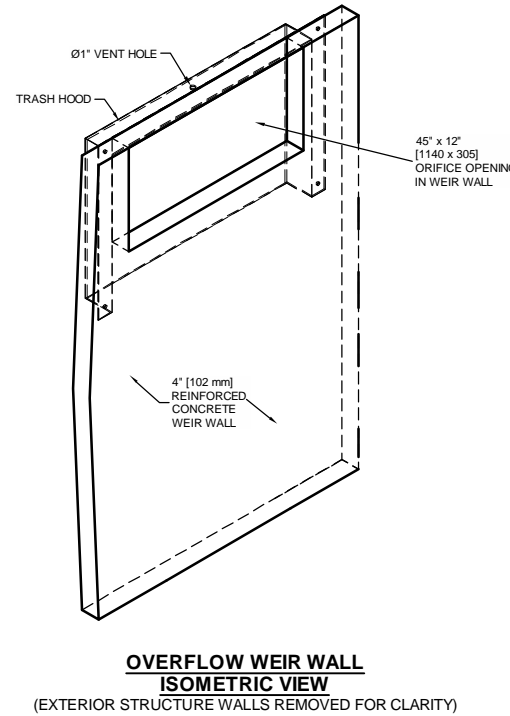

MATERIAL LIST

COUNT	DESCRIPTION	PROVIDED BY
XXX	54\"/>	

VAULT CAPACITY DATA

SEDIMENT STORAGE CAPACITY (L, CF)	6,880 L (243 CF)
OIL STORAGE CAPACITY (L, CF)	510 L (18 CF)

SITE SPECIFIC DATA REQUIREMENTS

JELLYFISH MODEL		JFVLAN-V			
STRUCTURE ID		*	*		
WATER QUALITY FLOW RATE (L/s)		*	*		
BYPASS FLOW RATE (L/s)		*	*		
PEAK FLOW RATE (L/s)		*	*		
RETURN PERIOD OF PEAK FLOW (yrs)		*	*		
MAX. DESIGNED BYPASS FLOW RATE (L/s)	263				
# OF CARTRIDGES REQUIRED (HF / DD)	*				
CARTRIDGE SIZE (inches)	*				
PIPE DATA:					
	I.E.	MAT'L	DIA	SLOPE %	HGL
INLET #1	*	*	*	*	*
INLET #2	*	*	*	*	*
OUTLET	*	*	*	*	*

* PER ENGINEER OF RECORD

XXX.XX INFORMATION TO BE SUPPLIED BY ENGINEER OF RECORD

FOR SITE SPECIFIC DRAWINGS PLEASE CONTACT YOUR LOCAL JELLYFISH FILTER REPRESENTATIVE. SITE SPECIFIC DRAWINGS ARE BASED ON THE BEST AVAILABLE INFORMATION AT THE TIME. SOME FIELD REVISIONS TO THE SYSTEM LOCATION OR CONNECTION PIPING MAY BE NECESSARY BASED ON AVAILABLE SPACE OR SITE CONFIGURATION REVISIONS. ELEVATIONS SHOULD BE MAINTAINED EXCEPT WHERE NOTED ON BYPASS STRUCTURE.

IMBRIUM
PROPOSAL
DRAWING

The design and information shown on this drawing is provided as a service to the project owner, engineer and contractor by Imbrium Systems Limited. It is not to be used, reproduced or modified in any manner without the prior written consent of Imbrium. Failure to conform to the design and information shown on this drawing is done at the user's own risk and Imbrium expressly disclaims any liability or responsibility for such use. If discrepancies between the supplied information and the actual field conditions are identified, the user shall be responsible for re-evaluation of the design. Imbrium accepts no liability for designs based on missing, incomplete or inaccurate information supplied by others.

NO.	REVISION	DATE	BY

JFVLAN-V-XX-XX
54" CARTRIDGES
Jellyfish
Langley Vault 5213

imbrium
407 FAIRVIEW DRIVE, WHITBY, ON L1N 4A9
TEL 800-565-4807 CA 416-890-9800 INTL +1-416-890-9800
Jellyfish® Filter
* THIS PRODUCT MAY BE SUBJECT TO VARIATIONS OF DESIGN

DATE:	XX/XX/XX
DESIGNED:	BSF
DRAWN:	BSF
CHECKED:	JSK
APPROVED:	SP
PROJECT NUMBER:	XXXXX
SHEET:	1 OF 2

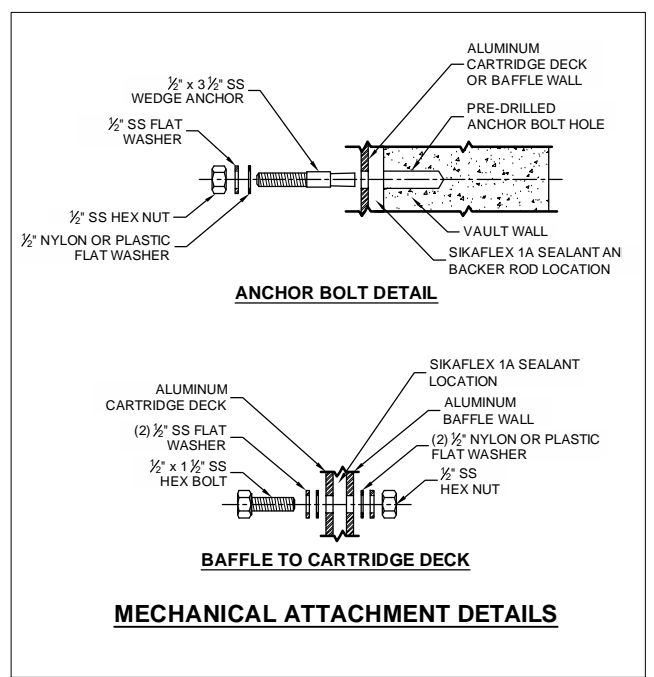
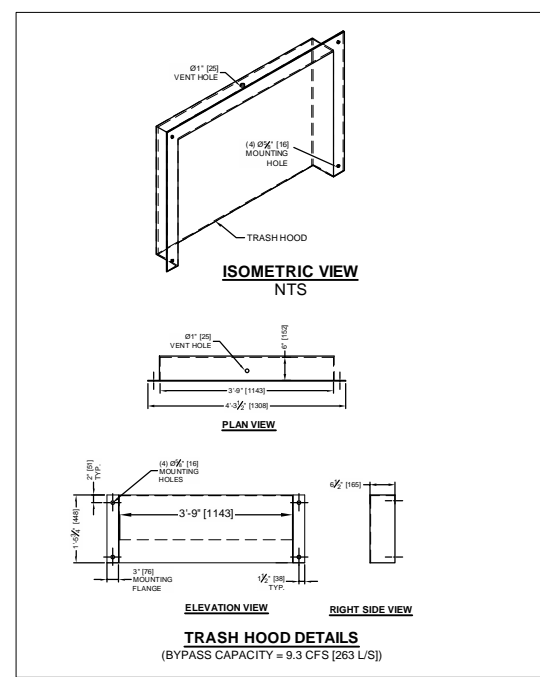
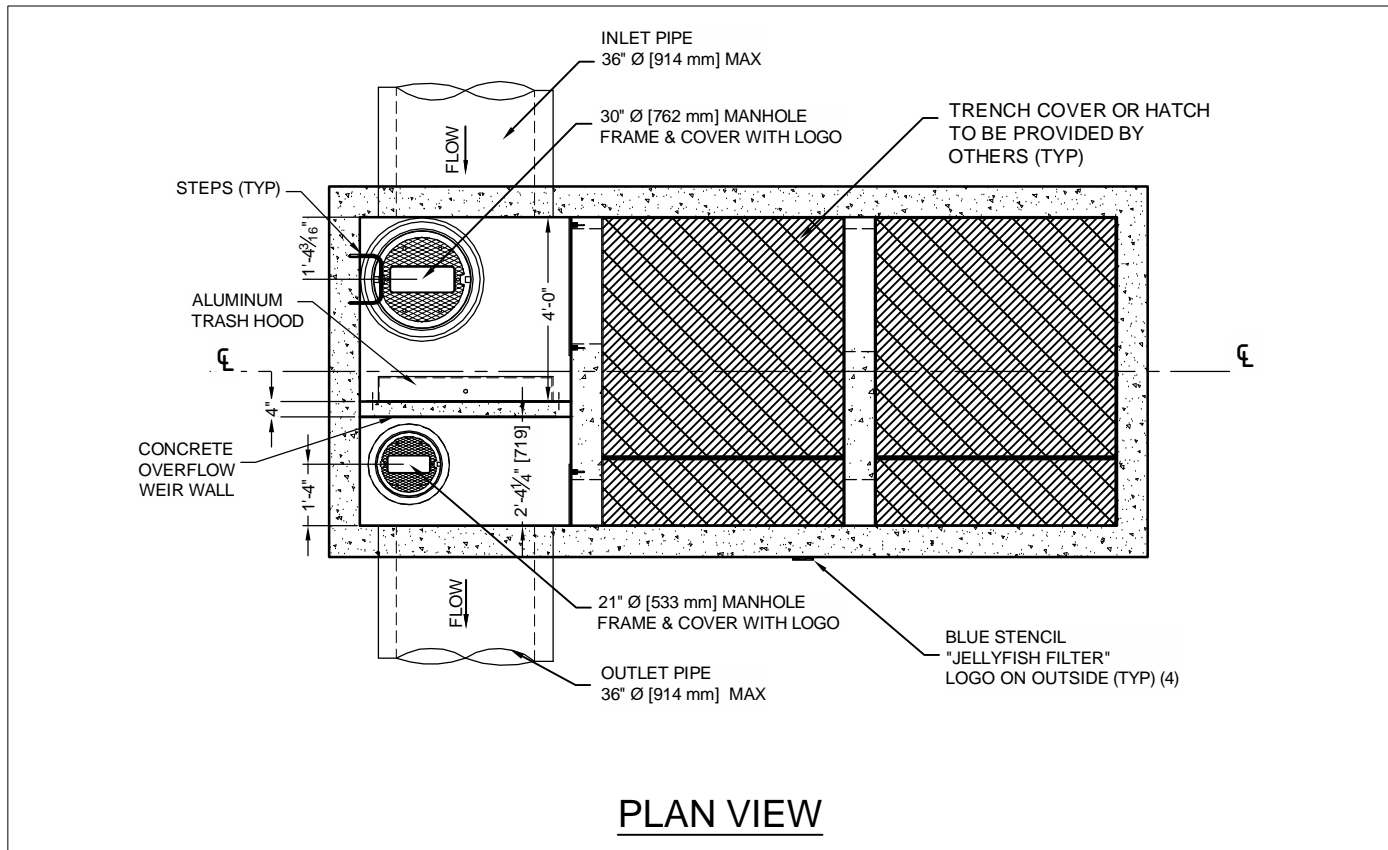
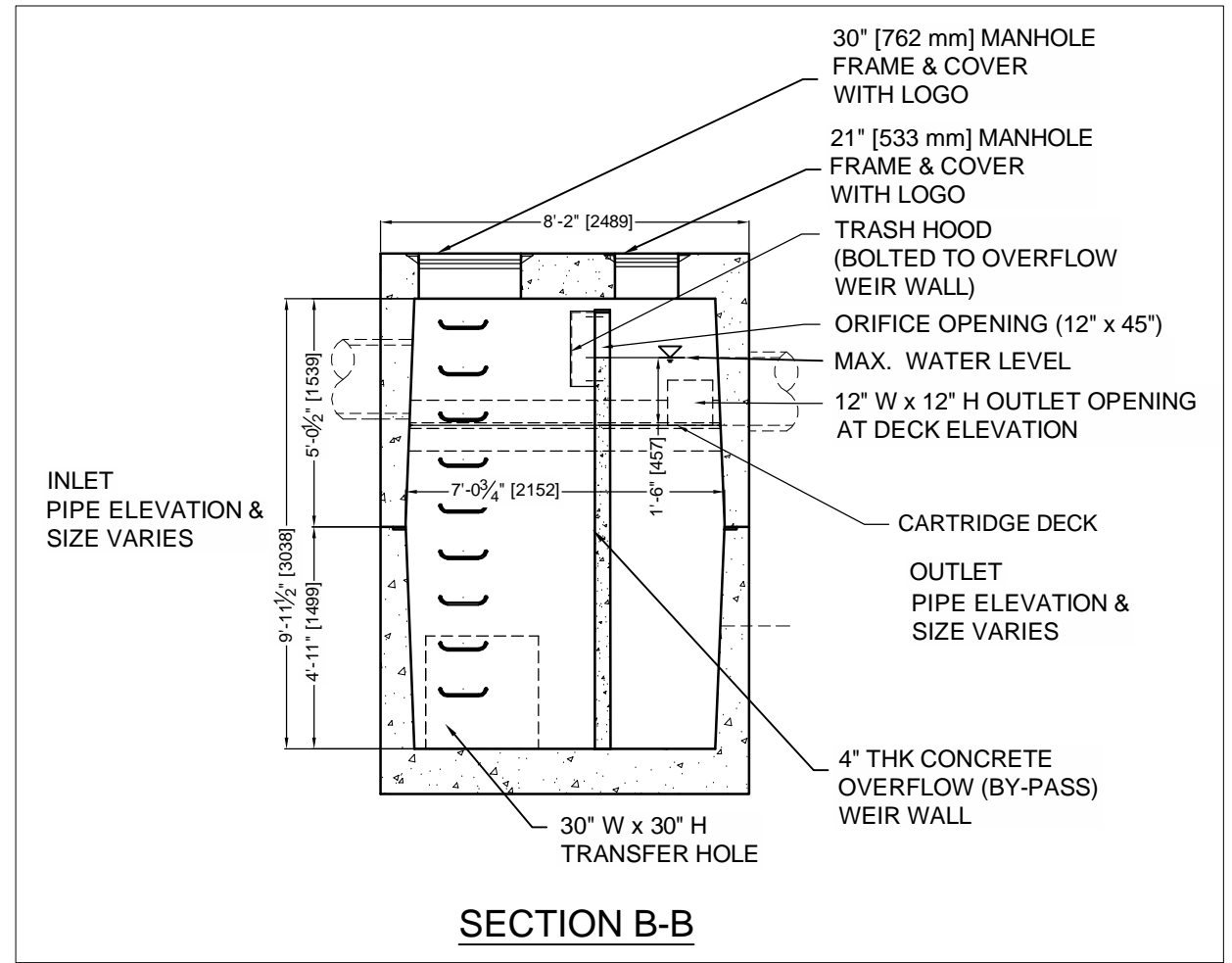
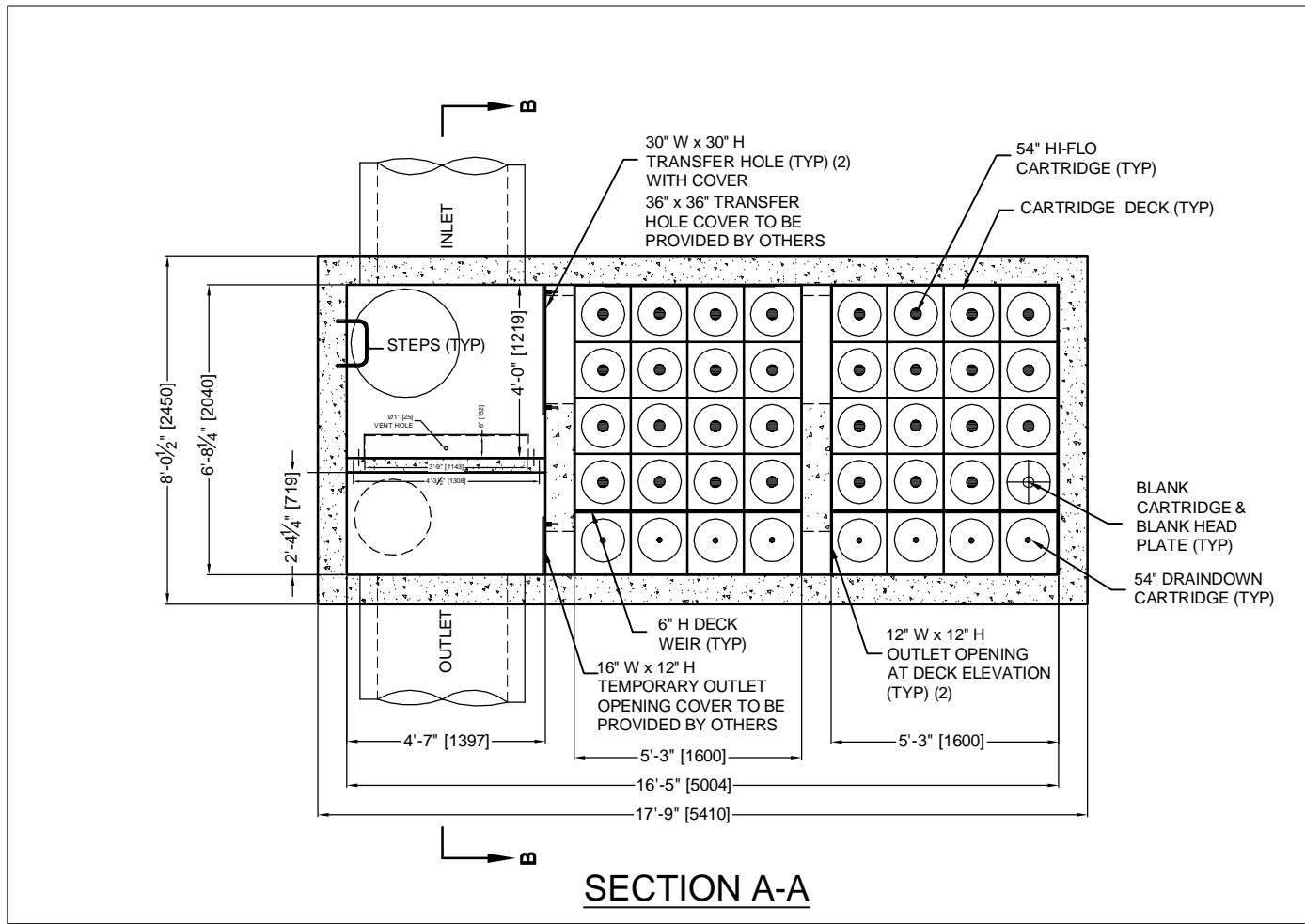

XXX.XX INFORMATION TO BE SUPPLIED BY ENGINEER OF RECORD

IMBRIUM
PROPOSAL
DRAWING

FOR SITE SPECIFIC DRAWINGS PLEASE CONTACT YOUR LOCAL JELLYFISH FILTER REPRESENTATIVE. SITE SPECIFIC DRAWINGS ARE BASED ON THE BEST AVAILABLE INFORMATION AT THE TIME. SOME FIELD REVISIONS TO THE SYSTEM LOCATION OR CONNECTION PIPING MAY BE NECESSARY BASED ON AVAILABLE SPACE OR SITE CONFIGURATION REVISIONS. ELEVATIONS SHOULD BE MAINTAINED EXCEPT WHERE NOTED ON BYPASS STRUCTURE.

The design and information shown on this drawing is provided as a service to the project owner, engineer and contractor by Imbrium Systems Limited. It is not to be used, reproduced or modified in any manner without the prior written consent of Imbrium. Failure to conform to the design and information shown on this drawing is done at the user's own risk and Imbrium expressly disclaims any liability or responsibility for such use. If discrepancies between the supplied information and the actual field conditions are noted, the user shall be responsible for re-evaluation of the design. Imbrium accepts no liability for designs based on missing, incomplete or inaccurate information supplied by others.

JFVLAN-V-XX-XX
54" CARTRIDGES

Jellyfish
Langley Vault 5213

imbrium
407 FAIRVIEW DRIVE, WHITBY, ON L1N 9A9
TEL 800-565-4807 CA 416-860-9800 INTL +1-416-860-9800
WWW.IMBRIUM.COM

Jellyfish Filter

DATE: XX/XX/XX
DESIGNED: BSF DRAWN: BSF
CHECKED: JSK APPROVED: SP
PROJECT NUMBER: XXXXX
SHEET: 2 OF 2