

**Plan View**

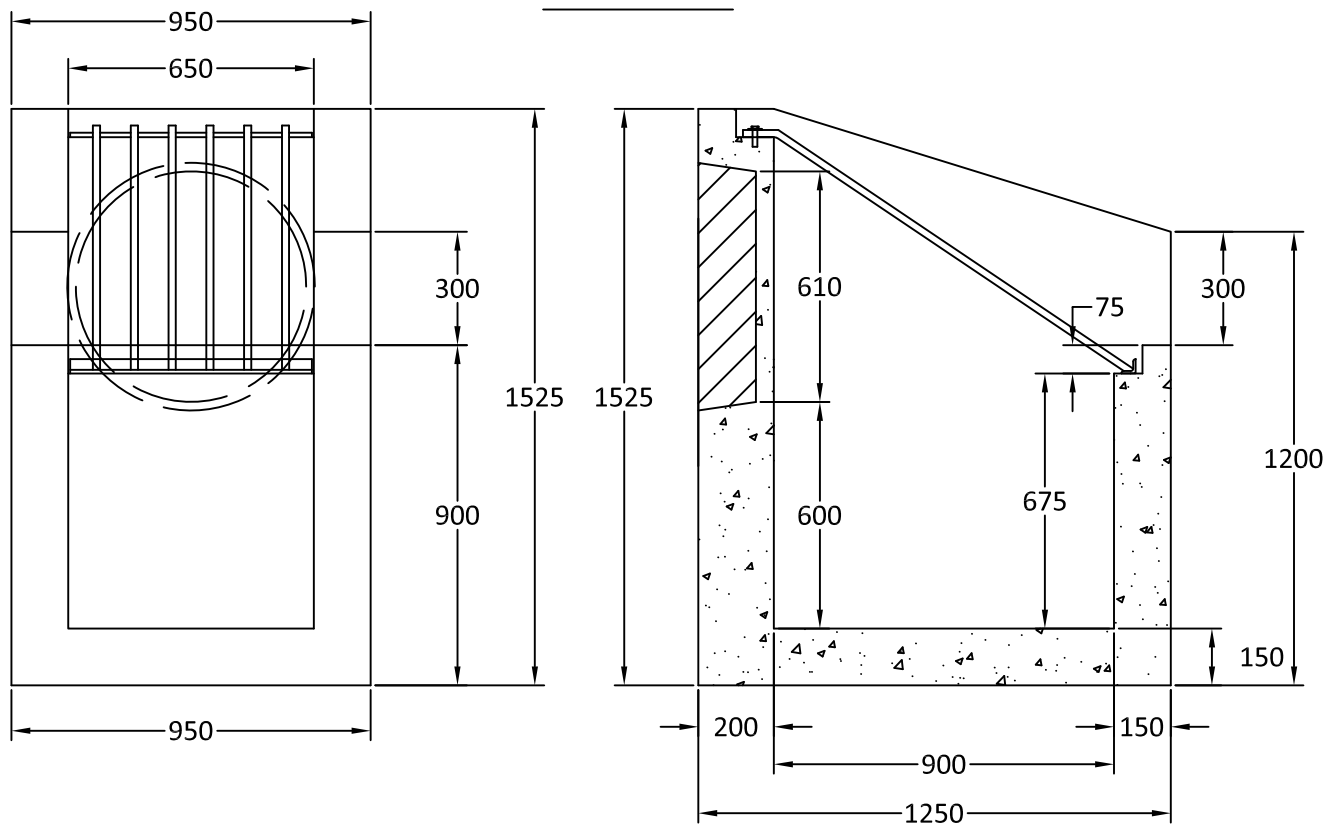

**Elevation View**

**Side View**

**Notes:**

1. HW SP582-04.01 is built as shown.  
[Note: SP582-04.01 HW is equivalent to SP219]
2. Unit supplied with  $\varnothing 610$  mm knockout core for inlet-outlet as shown.
3. Suggested core size to be a maximum of  $\varnothing 660$  mm concrete.
4. Bolt on hinged grills are available upon request.
5. Unit supplied with lifting inserts as required.
6. Approximate weight: 2,125 kg.
7. Minimum rebar yield strength: 414 MPa.
8. Minimum concrete strength: 30 MPa.
9. All dimensions are in millimeters.



Quality Assurance of products manufactured by The Langley Concrete Group has been verified by the following third party certification programs:



LANGLEY (604) 533-1656 VICTORIA (250) 478-9581 CHILLIWACK 1-800 667-9600

**DESCRIPTION:**

SO582-04.01 Headwall Structure

DRAWN BY: KS	JOB NO.:####-##
CHK BY: JAO/SW	DWG NO: HW-SP582-04.01
DATE: Mar.04, 2010	
SCALE: 1:20	REV.

This drawing is the property of the Langley Concrete Group of Companies. All information contained herein is confidential and may not be used in whole or in part without written permission from the owner.

LCG Products are held to the governing ASTM, and CSA specification & tolerances.