

Plan View

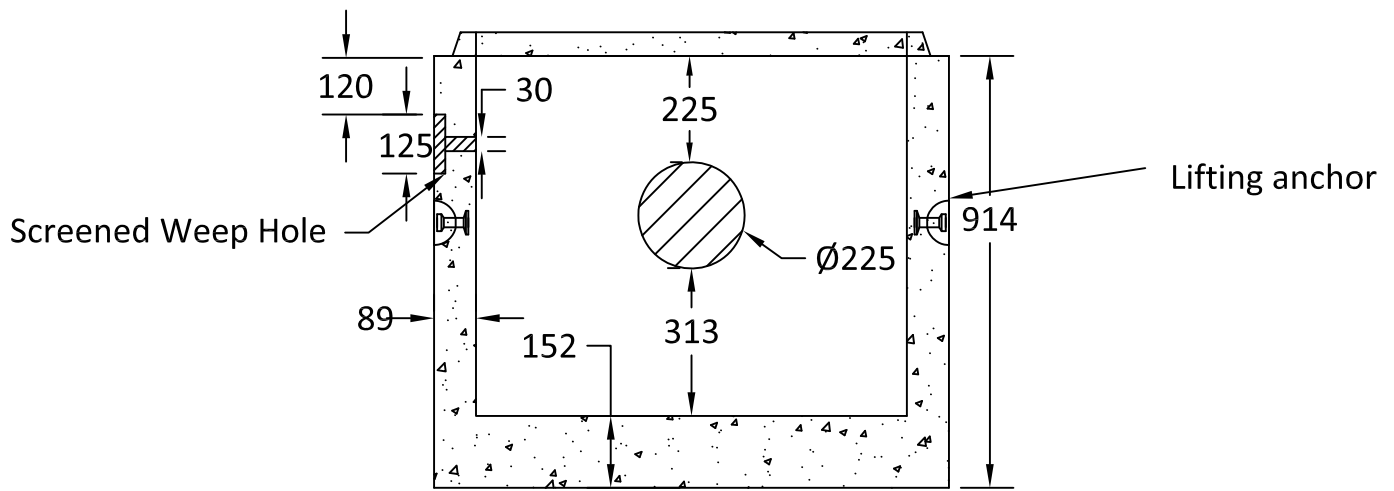

Section A-A

Notes:

1. Reinforced 900x900 catchbasin w/core as shown.
2. Core to be Ø225mm as shown.
3. Screened weeping hole provided as shown.
4. Lifting anchor supplied as shown.
5. Approx. weight: 1062 kg.
6. Min. concrete strength: 30MPa.



Quality Assurance of products manufactured by The Langley Concrete Group has been verified by the following third party certification programs:



www.langleyconcretegroup.com

DESCRIPTION:

900x900 C478
Catch Basin

LANGLEY (604) 533-1656 VICTORIA (250) 478-9581 CHILLIWACK 1-800 667-9600

DRAWN BY: JAO	JOB NO.: N/A
CHK BY:	DWG NO: CB0.9X0.9WB
DATE: Mar. 24, 2002	REV. A, JZ, AUG 20, 2018
SCALE: 1:16	LCG Products are held to the governing ASTM, and CSA specification & tolerances.
<small>This drawing is the property of the Langley Concrete Group of Companies. All information contained herein is confidential and may not be used in whole or in part without written permission from the owner.</small>	