

PARTLIST			
ITEM	QTY	PART NUMBER	WEIGHT
1	1	Headwall	3,700kg.

- Notes:
1. 14-15 Headwall is built as shown.
 2. Unit supplied with rough core for inlet/outlet as shown.
 3. Suggested core size to be maximum of 1200mm diameter.
 4. Structure supplied with embedded threaded inserts for grills and handrails.
 5. Bolt-on inlet/outlet grills and handrails are available upon request.
 6. Unit supplied with lifting inserts as required.
 7. Minimum rebar yield strength: 414 MPa.
 8. Minimum concrete strength: 30 MPa.
 9. All dimensions are in millimeters.

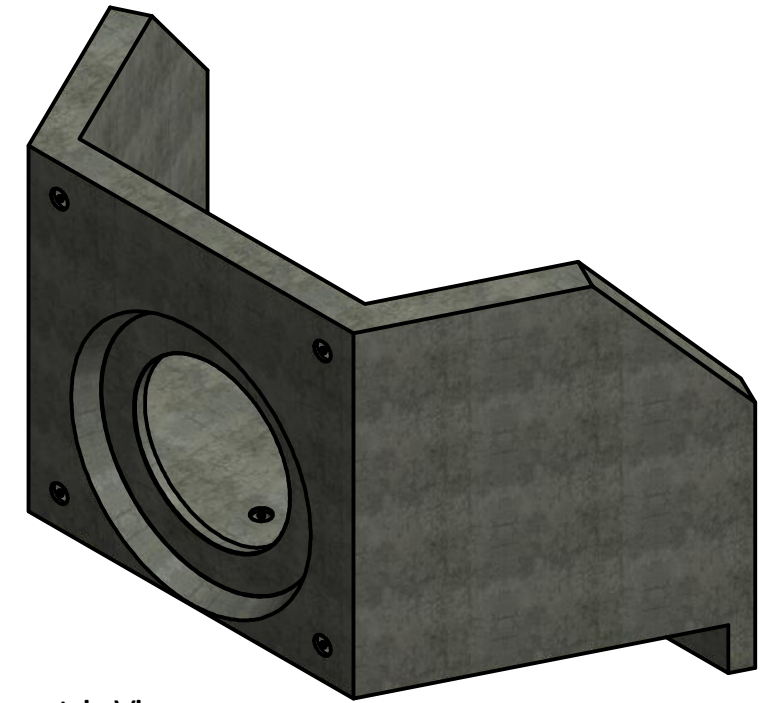

Isometric View

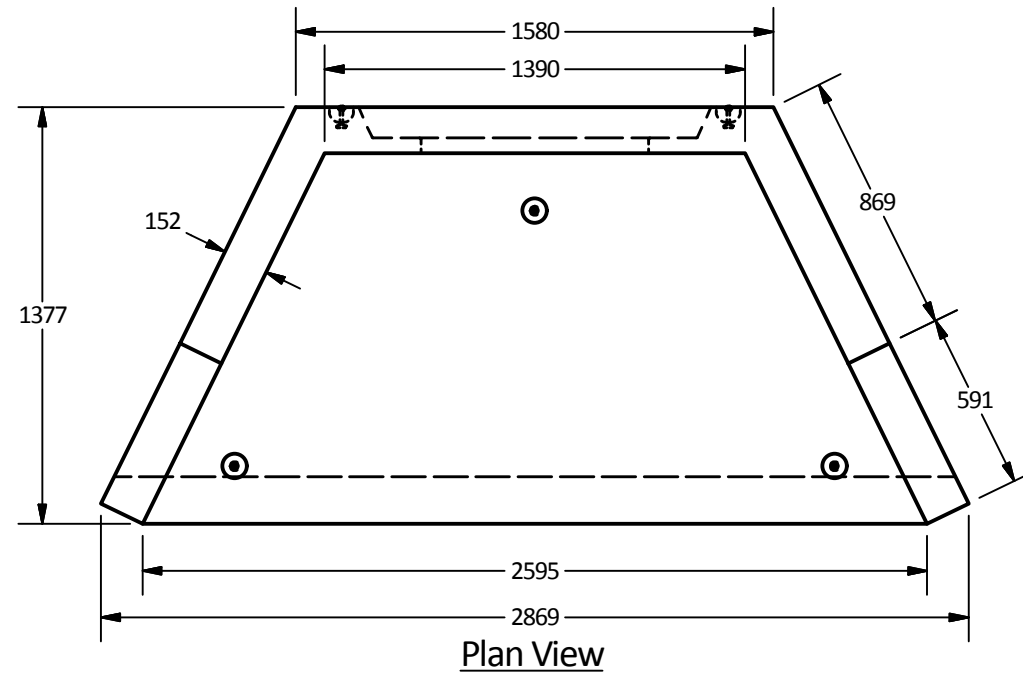
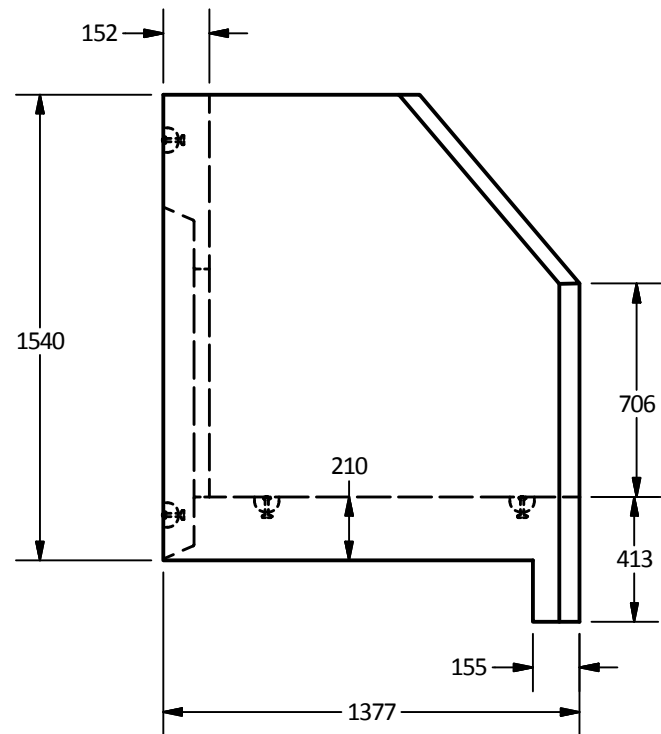

Side View

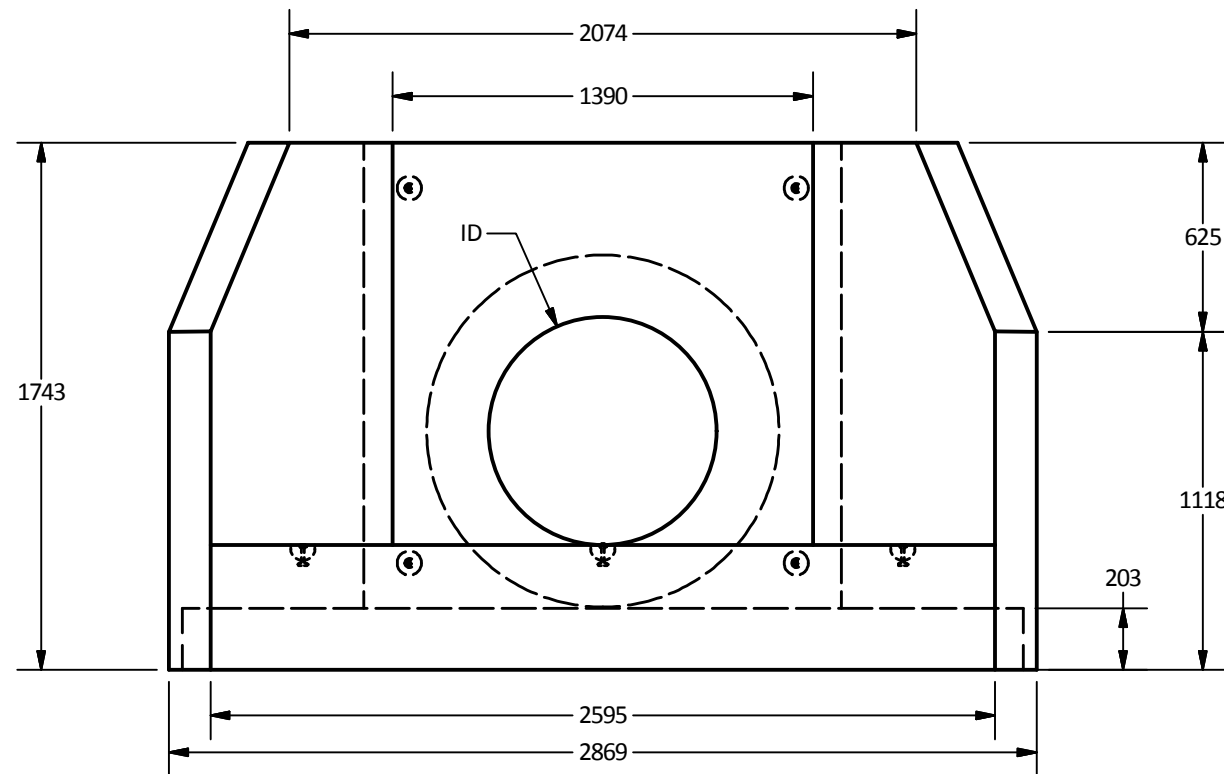

Elevation View

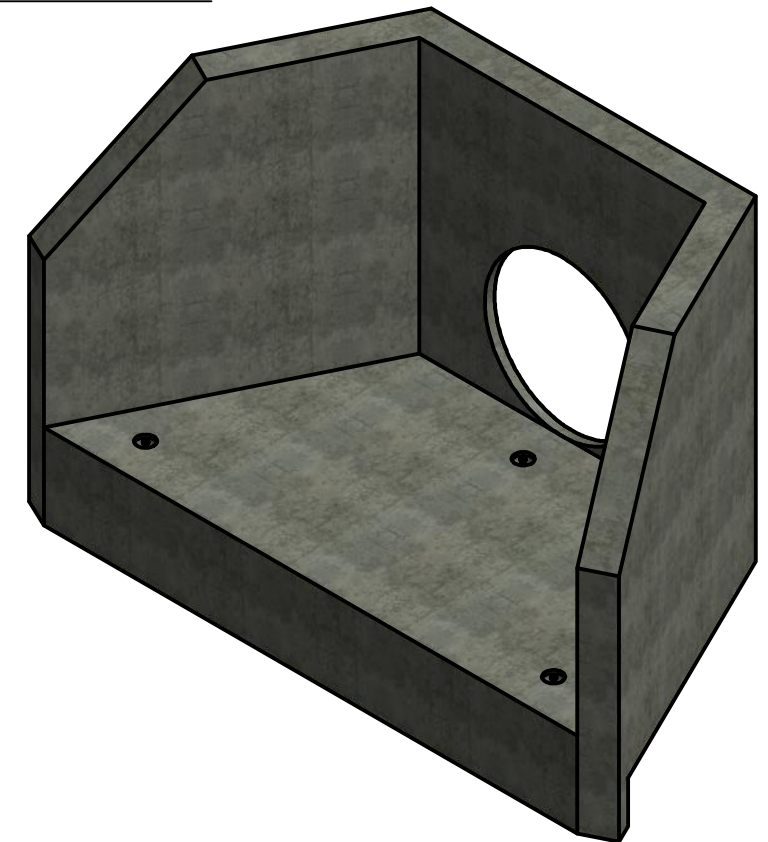

Langley Concrete Group is a certified Q-Cast Plant, an American Concrete Pipe Association Third Party Certification for the manufacture of Pipe, Manhole, Box Culvert & Precast Items.



Quality Assurance of products manufactured by The Langley Concrete Group has been verified by the following third party certification programs



All Dimensions are in Millimeters. Unless otherwise Stated

Projection Method: THIRD ANGLE



THE Langley CONCRETE GROUP
www.langleyconcretegroup.com
LANGLEY (604) 533-1656
VICTORIA (250) 478-9581
CHILLIWACK 1-800 667-9600

This drawing is the property of the Langley Concrete Group of Companies. All information contained herein is confidential and may not be used in whole or in part without written permission from the owner

DESCRIPTION:

14-15 Headwall Structure

DRAWN BY: SR

CHK BY: KS

DATE: July.23, 2018

SCALE: 1:25

SIZE: 11 x 17

REV.

JOB NO.

DWG NO: HW-14-15

SHEET 1 OF 1