

Plan View

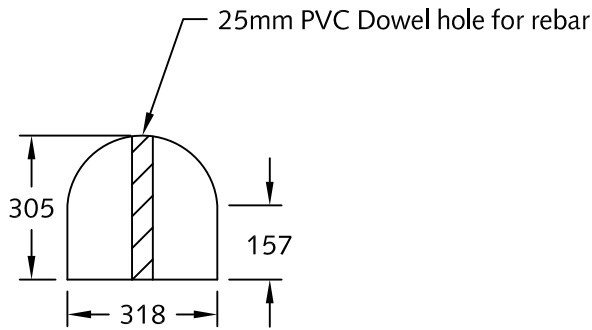

End View N.T.S.

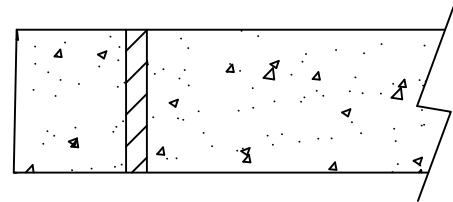

Section A-A

Notes:

1. Custom parking curb available as a non-stock item.
2. 25mm PVC dowels to be supplied as shown.
3. Special design curb to be 2135(l)x318(w)x305(h) as shown.
4. Approx. weight: 150 Kgs.
5. Min. concrete strength: 35MPa.



Quality Assurance of products manufactured by The Langley Concrete Group has been verified by the following third party certification programs:



DESCRIPTION:

Custom Parking Curb
2.1m Length

DRAWN BY: JAO DRAWING NO: PC-3.0

SCALE: 1:16

DATE: Dec/16/2009

This drawing is the property of the Langley Concrete Group of Companies. All information contained herein is confidential and may not be used in whole or in part without written permission from the owner.

LCG Products are held to the governing ASTM, and CSA specification & tolerances.

LANGLEY (604) 533-1656 VICTORIA (250) 478-9581 CHILLIWACK 1-800 667-9600