

PART LIST			
ITEM	QTY	PART NUMBER	WEIGHT
1	1	Type A Pole Base	620 kg. (1200mm Height)
2	3	2.5T x 65 Lifting Inserts	
3	4	25 x 920 Galvanized Anchor Bolts	

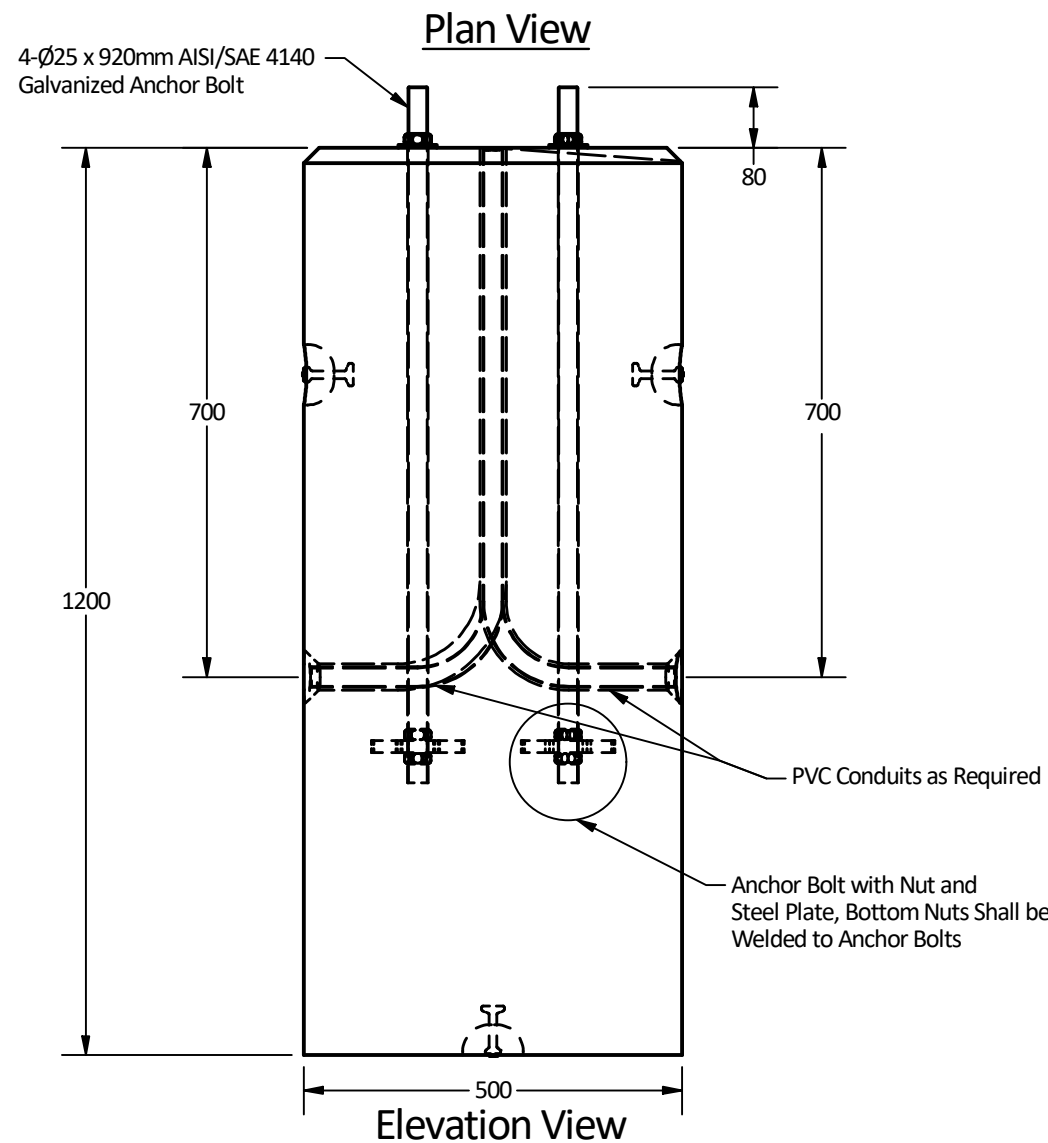
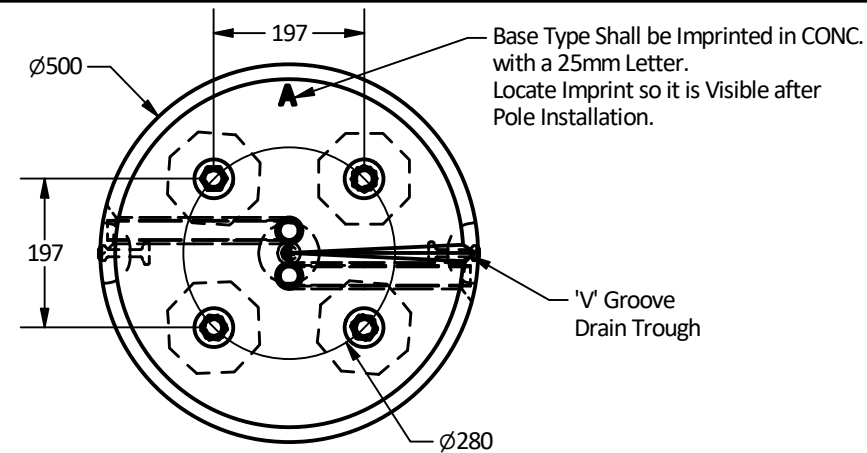

- Notes:
- 1200mm concrete pole base to be built as shown.
  - Unit supplied with 4- $\varnothing$ 25 x 920mm, 197mm c/c AISI/SAE 4140 galvanized anchor bolts as shown. For more detail see MOTI DWG#SP635-1.1.2, SP635-1.4.1 to SP635-1.4.4.
  - Unit supplied with lifting inserts as required.
  - Unit supplied with nuts and washers as required.
  - Unit supplied with conduits as required.
  - Minimum concrete strength: 30 MPa.
  - All dimensions are in millimeters.
  - Installation & backfilling is the responsibility of others.
  - V- Groove Drain Trough to Start at Zero Depth in Centre of Base to 10mm at the Outside edge. Align with Conduit.

**Note: 25mm Spacing Between Conduit**

Langley Concrete Group is a certified Q-Cast Plant, an American Concrete Pipe Association Third Party Certification for the manufacture of Pipe, Manhole, Box Culvert & Precast Items.



Quality Assurance of products manufactured by The Langley Concrete Group has been verified by the following third party certification programs



All Dimensions are in Millimeters. Unless otherwise Stated

Projection Method: THIRD ANGLE



The LANGLEY CONCRETE Group of Companies  
 www.langleyconcretegroup.com  
 LANGLEY (604) 533-1656  
 VICTORIA (250) 478-9581  
 CHILLIWACK 1-800 667-9600

This drawing is the property of the Langley Concrete Group of Companies. All information contained herein is confidential and may not be used in whole or in part without written permission from the owner

DESCRIPTION:

Precast Concrete Pole Base  
 Type A  
 MOTI Specification

DRAWN BY:	BY	JOB NO.
CHK BY:	KS	DWG NO: LPB-TYPE A-MOTI
DATE:	Dec.19, 2019	LC NO:
SCALE:	1:10	MU NO:
SIZE	11 x 17	REV.
		SHEET 1 OF 1