

Note:

1. Ø1050 Manhole manufactured to ASTM C478 specification.
2. Concrete designed to withstand HS20, BCL 625 live loadings.
3. Unit supplied with cores as required.
4. Unit supplied with ladder rungs as required.
5. Unit supplied with lifting insert as required.
6. Unit supplied with access opening as required.
7. WWF minimum yield strength: 448 MPa.
8. Minimum rebar yield strength: 414 MPa.
9. Minimum concrete strength:
 - MH Barrel: 30 MPa.
 - Lid & Base: 35 MPa.
10. All reinforcing to have minimum 25 mm of concrete cover.
11. All dimensions are in millimeters.

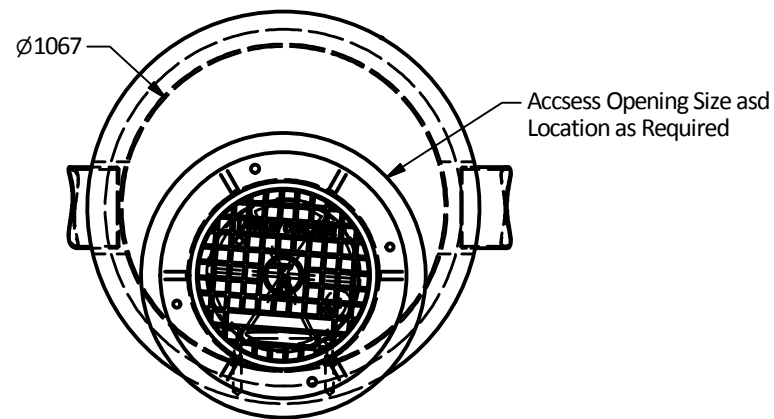

Plan View

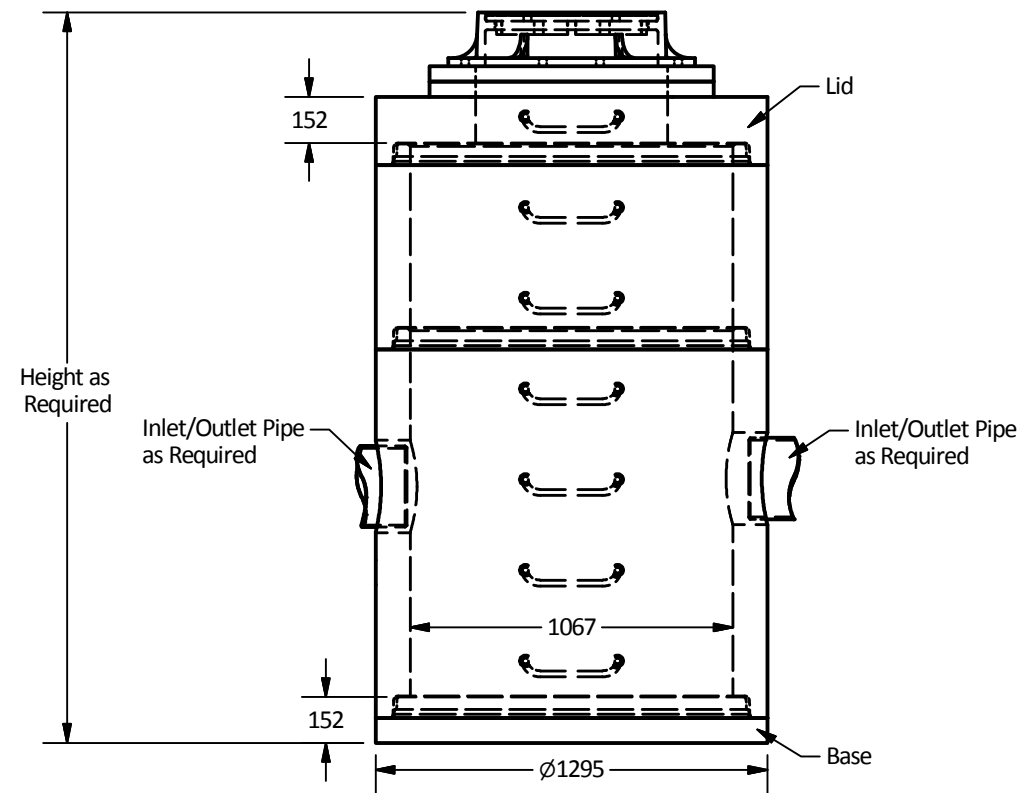

Elevation View

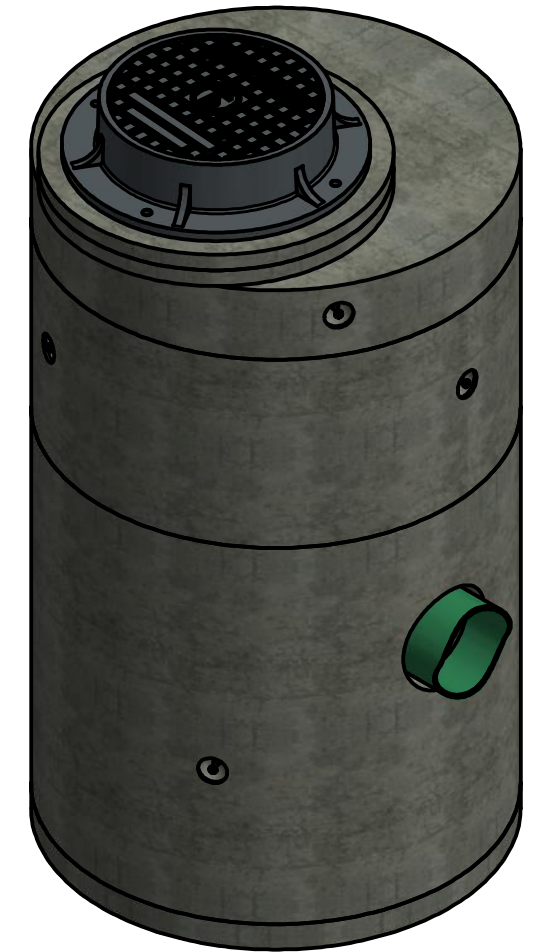

Isometric View

PART LIST			
ITEM	QTY	PART NUMBER	WEIGHT
1	1	MH 1050 Lid	555 kg.
2	1	1050 Base	465 kg.
3	As Required	1050 Manhole	1,116 kg/m.

Langley Concrete Group is a certified Q-Cast Plant, an American Concrete Pipe Association Third Party Certification for the manufacture of Pipe, Manhole, Box Culvert & Precast Items.



Quality Assurance of products manufactured by The Langley Concrete Group has been verified by the following third party certification programs



All Dimensions are in Millimeters. Unless otherwise Stated

Projection Method: THIRD ANGLE



LANGLEY (604) 533-1656
VICTORIA (250) 478-9581
CHILLIWACK 1-800 667-9600

This drawing is the property of the Langley Concrete Group of Companies. All information contained herein is confidential and may not be used in whole or in part without written permission from the owner

DESCRIPTION:

Ø1050 Mahnole

DRAWN BY: SR	JOB NO.
CHK BY: KS	DWG NO: MH-1050
DATE: Sep.14, 2017	
SCALE: 1:25	
SIZE 11 x 17	REV.
	SHEET 1 OF 1