

| PART LIST |     |                |           |
|-----------|-----|----------------|-----------|
| ITEM      | QTY | PART NUMBER    | WEIGHT    |
| 1         | 1   | Type III Vault | 7,100 kg. |
| 2         | 1   | Type III Lid   | 2,730 kg. |

Notes:

- Type III Oil interceptor manufactured to meet AASHTO HS20/BCL-625 live loading.
- Lid designed to withstand AASHTO HS20 / BCL-625 live loading.
- Concrete vault designed for the following earth covers:
  - Minimum: 0 m.
  - Maximum: 2.5 m.
- Unit supplied with Ø610mm knockout cores for inlet/outlet as shown.
- Unit supplied with lifting inserts as required.
- Unit risers available in heights: 305, 450 etc up to 1800mm maximum.
- Design can be modified for specific sites, please contact LCG sales office.
- Unit to have 4-Ø51 mm vent holes as shown.
- Unit supplied with galvanized baffles as shown.
- Unit has a maximum 3,000 liter [3.0 m<sup>3</sup>] capacity.
- Unit design to:
  - Temp.: 0°C.
  - Oil S.G.: 0.85
  - Influent oil = 100 mg/l.
  - Effluent oil <=15 mg/l.
  - Max. flow: 22 l/sec.
- Minimum rebar yield strength: 414 MPa.
- Minimum concrete strength: 35 MPa.
- PVC T required by design, supplied and installed by others in field.
- All dimensions are in millimeters.

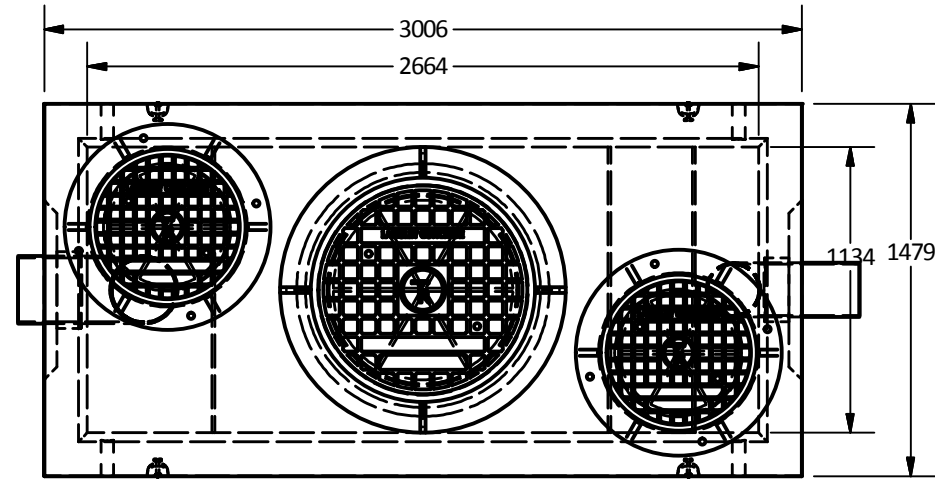

Plan View

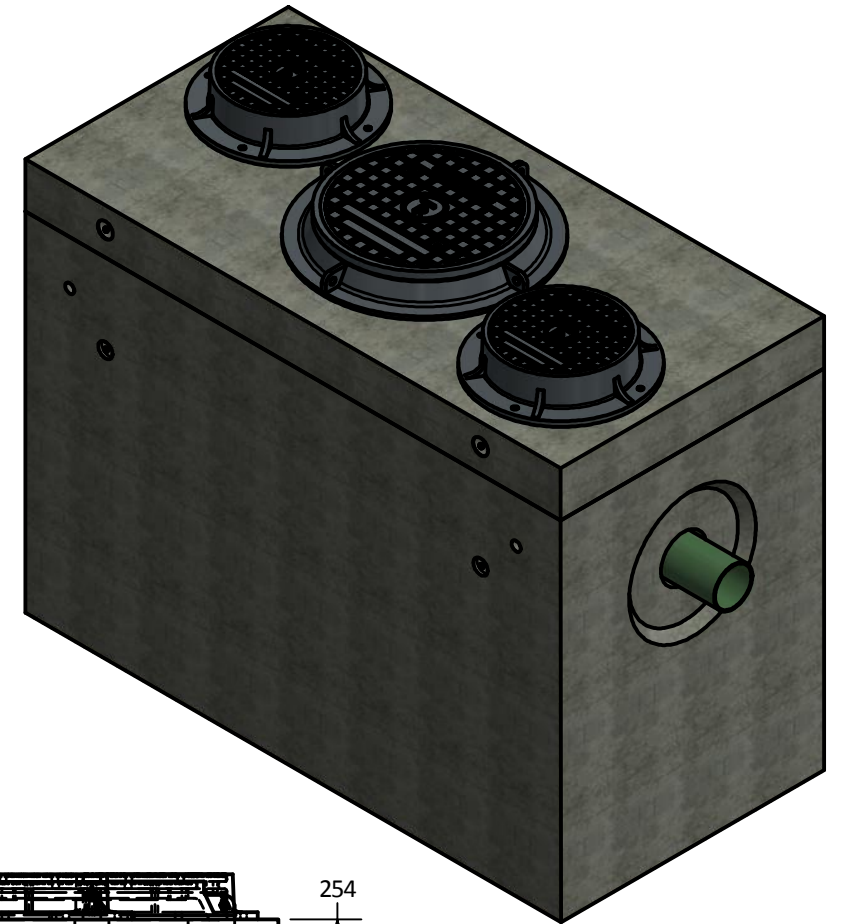

Isometric View

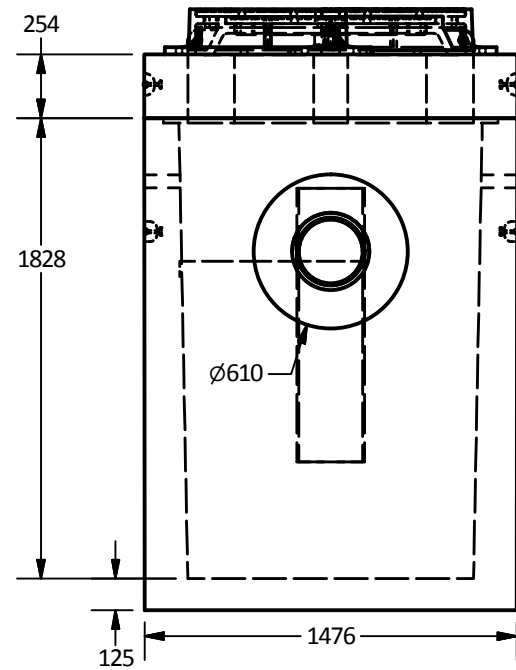

East View

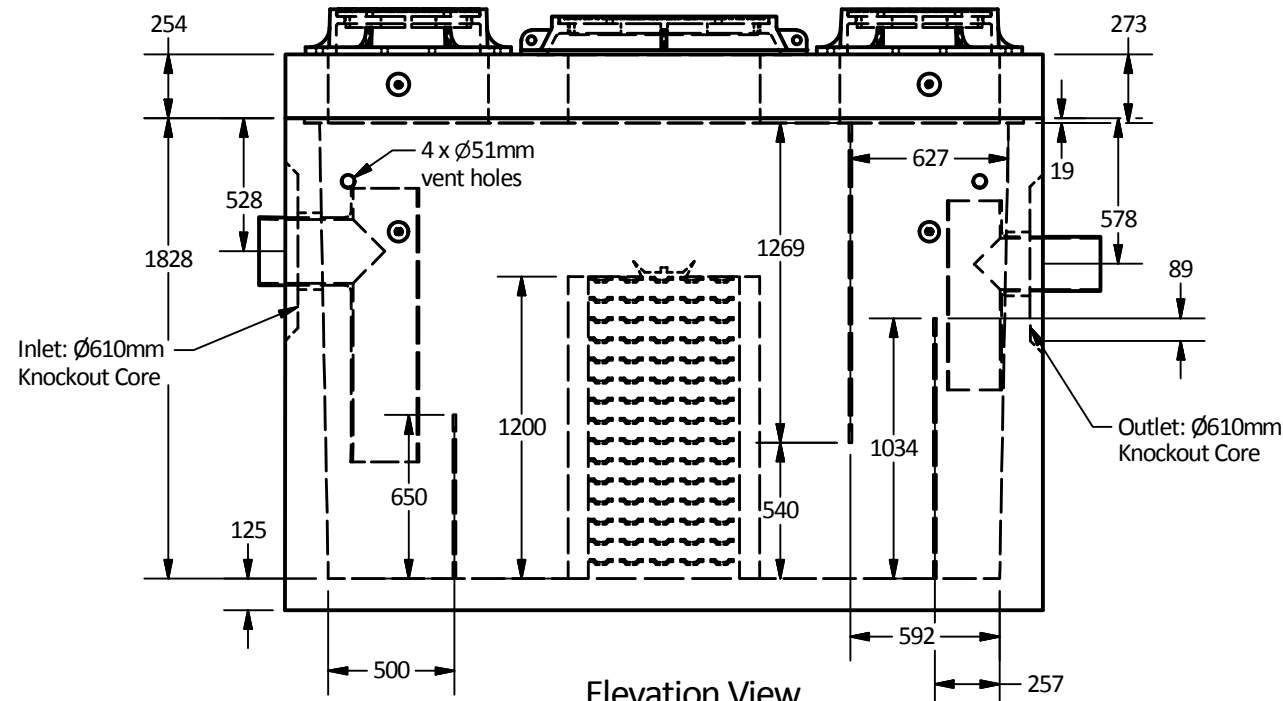

Elevation View

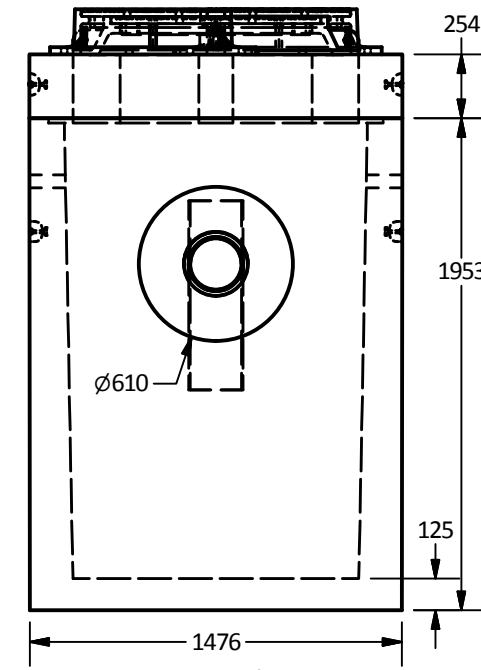

West View

Coalescing Plate has not been shown for clarification in plan view and side views

Total of 16 Coalescing Media Units to be Supplied for this Order

Langley Concrete Group is a certified Q-Cast Plant, an American Concrete Pipe Association Third Party Certification for the manufacture of Pipe, Manhole, Box Culvert & Precast Items.



Quality Assurance of products manufactured by The Langley Concrete Group has been verified by the following third party certification programs



All Dimensions are in Millimeters. Unless otherwise Stated

Projection Method: THIRD ANGLE



LANGLEY (604) 533-1656  
VICTORIA (250) 478-9581  
CHILLIWACK 1-800 667-9600

This drawing is the property of the Langley Concrete Group of Companies. All information contained herein is confidential and may not be used in whole or in part without written permission from the owner

DESCRIPTION:

Type III Coalescing Plate Oil Interceptor  
8mm Spacing

|                       |                           |
|-----------------------|---------------------------|
| DRAWN BY:<br>SR       | JOB NO.                   |
| CHK BY:<br>KS         | DWG NO:<br>TYPE III-COI-8 |
| DATE:<br>Sep.27, 2018 |                           |
| SCALE:<br>1:30        |                           |
| SIZE<br>11 x 17       | REV.                      |
|                       | SHEET 1 OF 1              |