

Bell & Spigot Pipe (200 - 1200mm)

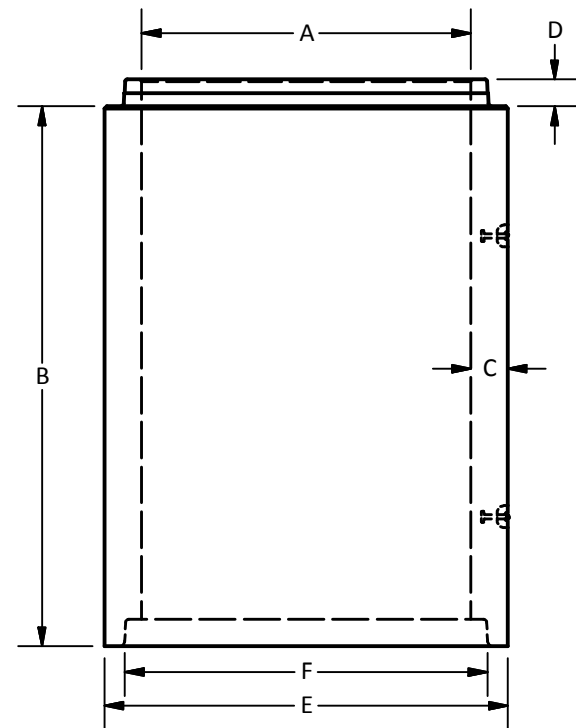

Straight Wall - Tongue & Groove Pipe (1350 - 3050 mm)

Notes:

1. Pipe manufactured to the following specifications:
 - Non-reinforced C14-3 pipe: ASTM C14M & CSA A257.1
 - Reinforced C76 pipe: ASTM C76-II, III, IV, V & CSA A257.2
2. 300-3050 mm pipe available with "SuperSeal" self lubricated gasket if required.
3. Sanitary tested pipe available upon request.
4. Min. concrete strengths to meet or exceed specific ASTM & CSA specs.
5. All dimensions are in millimeters.

**Limited availability, Contact LCG sales/engineering department for more details.

Langley Concrete Group - Mainland Pipe Dimensions

Pipe Diameter (mm) A	Pipe Length (m) B	Size of Wall	Wall Thickness (mm) C	Spigot Length (mm) D	Bell Width (mm) E	Bell Diameter (mm) F	Pipe Weight (kg/m)
200	1.22	B Wall	32	81	342	258	77
250	1.22	B Wall	51	86	425	324	130
300	2.5	B Wall	57	90	508	389	190
375	2.5	B Wall	57	90	606	478	230
450	2.5	B Wall	64	95	702	571	300
525	2.5	C Wall	89	95	803	659	390
600	2.5	C Wall	95	98	905	748	580
675	2.5	C Wall	102	98	1006	836	710
750	2.5	C Wall	108	98	1095	914	800
900	2.5	C Wall	121	98	1299	1092	1060
1050	2.5	C Wall	133	118	1500	1274	1320
1200	2.5	C Wall	146	121	1683	1452	1635
1350	2.5/3.05	C Wall	159	112	1689	1526	1850
1500	2.5/3.05	C Wall	171	121	1873	1691	2200
1650**	2.5/3.05	C Wall	184	127	2045	1823	2625
1800	2.5/3.05	C Wall	196	132	2228	2021	3050
2100	2.44	C Wall	203	143	2346	2320	3700
2400	2.5/3.05	B Wall	225	130	2888	2638	4615
3050	2.5/3.05	C Wall	298	160	3651	3327	7785

Langley Concrete Group is a certified Q-Cast Plant, an American Concrete Pipe Association Third Party Certification for the manufacture of Pipe, Manhole, Box Culvert & Precast Items.



Quality Assurance of products manufactured by The Langley Concrete Group has been verified by the following third party certification programs



All Dimensions are in Millimeters. Unless otherwise Stated

Projection Method: THIRD ANGLE



LANGLEY (604) 533-1656
VICTORIA (250) 478-9581
CHILLIWACK 1-800 667-9600

This drawing is the property of the Langley Concrete Group of Companies. All information contained herein is confidential and may not be used in whole or in part without written permission from the owner

DESCRIPTION:

Mainland B.C. Pipe Details

DRAWN BY: SR JOB NO.

CHK BY: KS DWG NO: P-1.0

DATE: July.31, 2018

SCALE: 1:35

SIZE: 11 x 17

REV. SHEET 1 OF 1