

PART LIST			
ITEM	QTY	PART NUMBER	WEIGHT
1	1	1.5 x 1.5 BOX	2,800 kg.
2	1	1.5 x 1.5 LID	1000 kg.

Notes:

- 1.5 x 1.5 vault is built as shown.
- Unit designed to withstand AASHTO HS20/BCL-625 live load.
- Concrete vault designed for following earth cover:
 - Minimum: 0m
 - Maximum: 2.5m.
- Unit supplied with 0.56 x 0.56 m square knockout core as shown.
- Unit supplied with 4 x unistrut P3370 as shown.
- Unit supplied with lifting insert as required.
- Unit supplied with ferrule inserts if required.
- Unit to have 0.165 x 0.165 x 0.125 m deep sump as shown.
- Lid supplied with opening for access as required.
- Unit supplied with 16 x Ø102mm cores for duct Terminator as shown.
- Unit supplied with 16 x Ø102 DB2 Duct Terminators as shown.
- Minimum rebar yield strength: 414 MPa.
- Minimum concrete strength: 30 MPa.
- Vault interior can be supplied with white paint for improved visibility/cleanliness and damproofed exterior using CS-55 or approved equivalent.
- All dimensions are in millimeters.

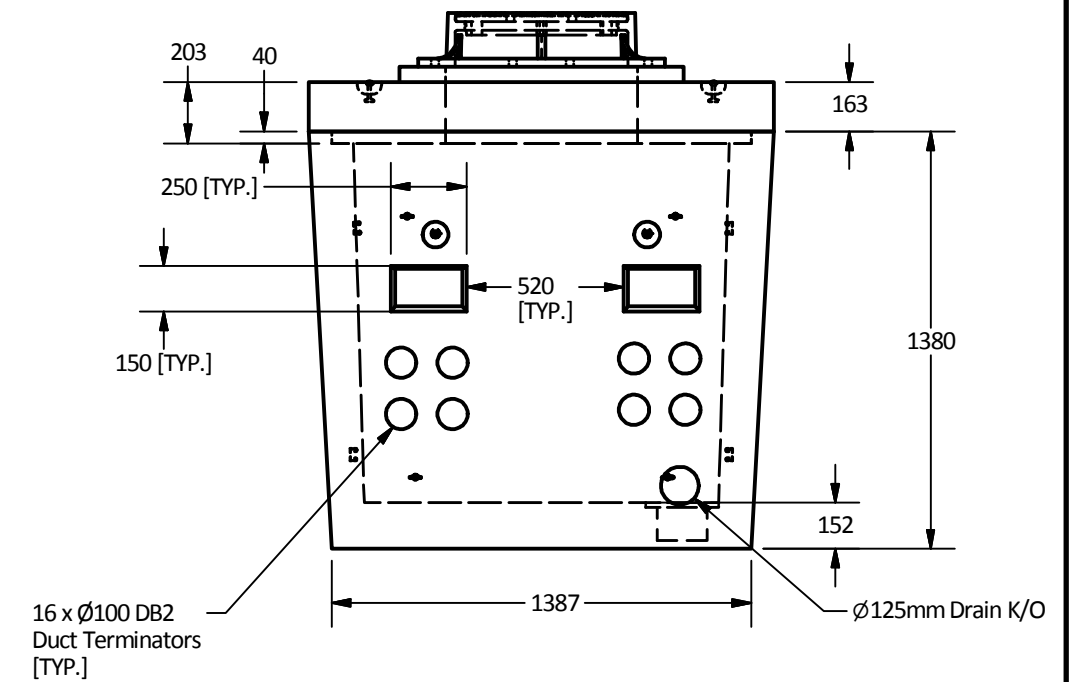
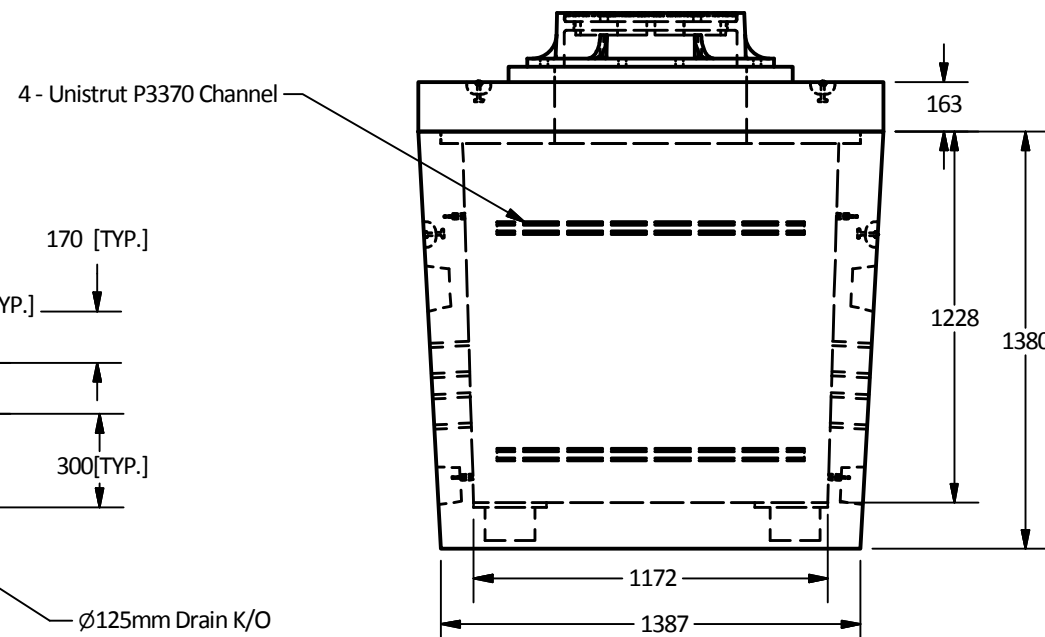
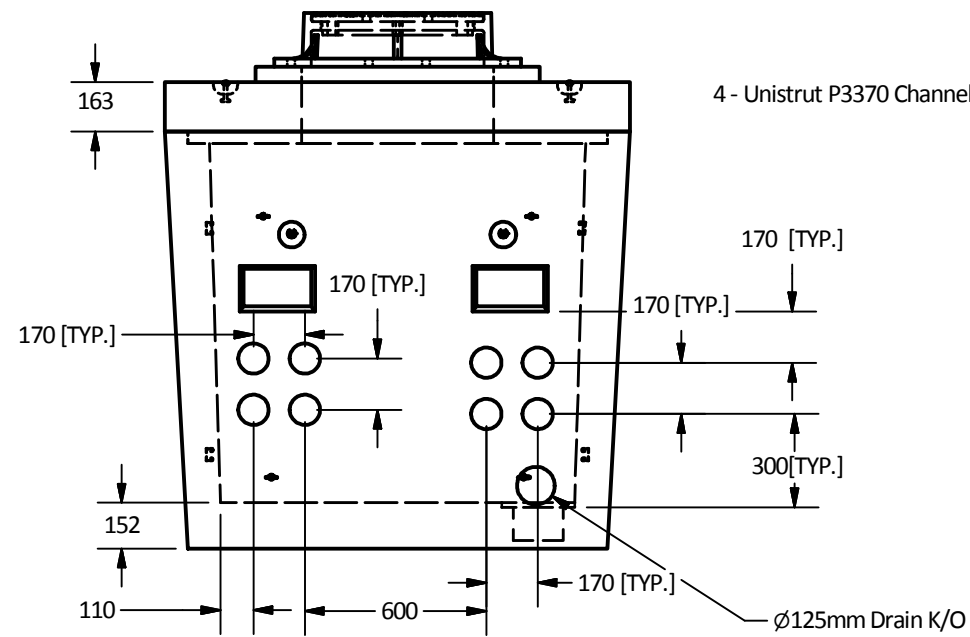
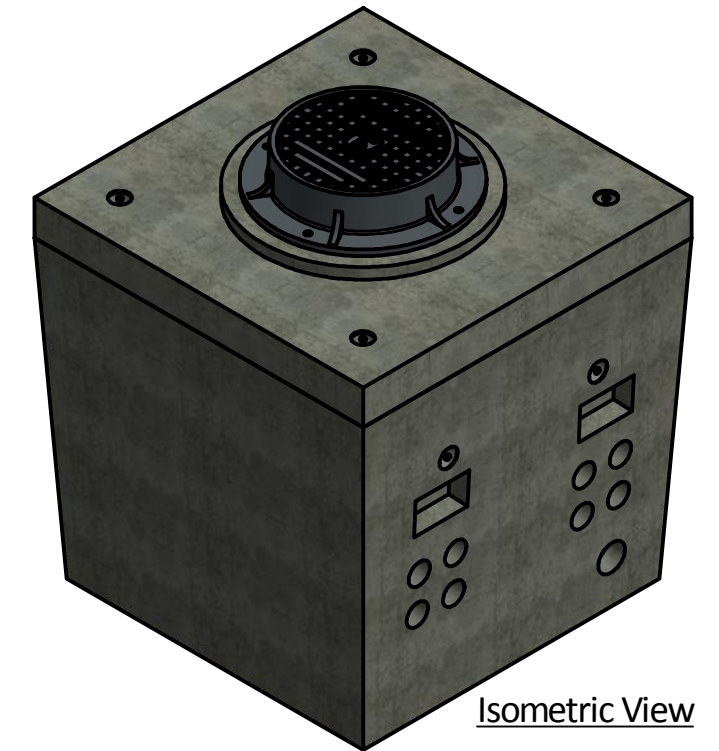
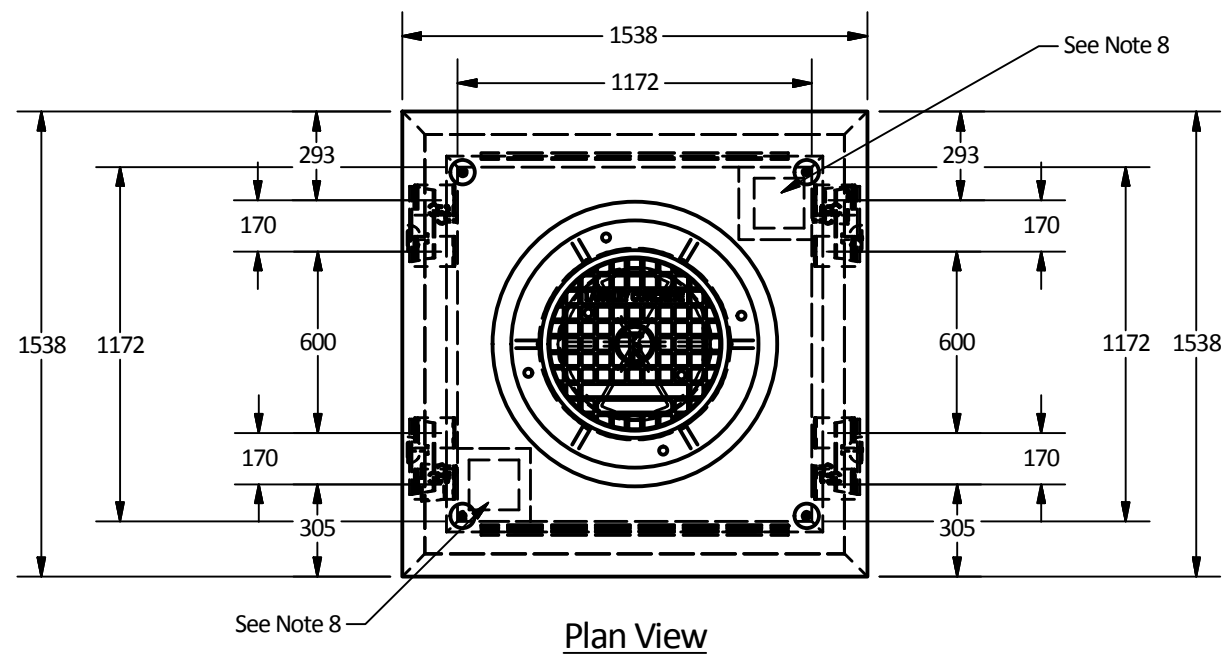

Langley Concrete Group is a certified Q-Cast Plant, an American Concrete Pipe Association Third Party Certification for the manufacture of Pipe, Manhole, Box Culvert & Precast Items.



All Dimensions are in Millimeters. Unless otherwise Stated

Projection Method: THIRD ANGLE



This drawing is the property of the Langley Concrete Group of Companies. All information contained herein is confidential and may not be used in whole or in part without written permission from the owner



Quality Assurance of products manufactured by The Langley Concrete Group has been verified by the following third party certification programs



DESCRIPTION:

Tel Communication Vault
1.5 x 1.5 VAULT

DRAWN BY: SR		JOB NO.
CHK BY: KS		DWG NO: V 1.5 x 1.5-TEL-COM
DATE: Aug.16, 2018		
SCALE: 1:25		
SIZE 11 x 17	REV.	SHEET 1 OF 1